



**Chroma**

Benvenuti a tutti  
Welcome all

Giakova Italy

Freek Dillingh, technical trainer BTS



Chroma

One-stop EIS measurement solution  
for battery cells

Perché integrare le misure EIS nei ciclatori di celle?

Freek Dillingh, technical trainer BTS

1. Test requirements background
2. Practical challenges of EIS testing
3. Chroma EIS Solution Features
4. Function Usage Introduction
5. Product Specifications



# 1. Test requirements background

# 1. What is a cell and what does it do?

A cell is an electrochemical system.

It converts stored chemical energy into electrical energy through reactions.

# 1. A cell and its resistance? Linear /dynamic ?

## Cell resistance is a dynamic value:

The resistance tells us more about the cell health, performance and safety.

Lithium-ion (Li-ion) battery cells become less efficient over time and with use (degradation).

Increasing load cycles result in higher internal resistance

Cell resistance is dependent on the frequency

DC (0 Hz)

Low frequencies 0.01 – 10 Hz most harmful accelerate cell degradation

Middle frequencies 100 Hz to 10 kHz partially effect dependent on signal amplitude

High frequencies above 10 kHz almost no harmful effect (can be used to heat up the cell internally).

For good cell analysis a frequency sweep is mandatory.

# 1. ECM (Equivalent Circuit Model) Li-Ion cell.

To simulate the voltage at the cell terminals when an electric current is applied to discharge or recharge it.

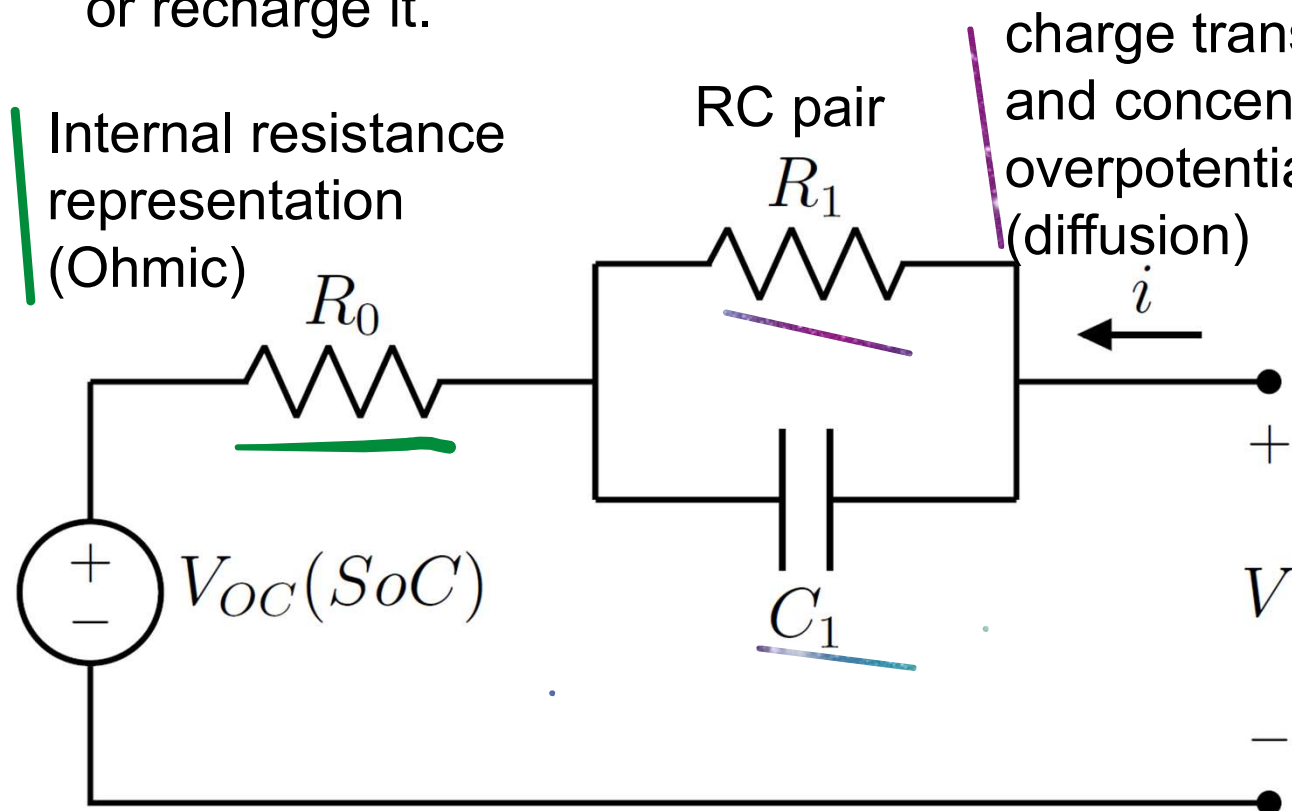

electrolyte resistance, separator and current collectors (contact resistance)

$R_o$  Ohmic res  
 $R_p$  polarization resistance (during electrochemical reaction)

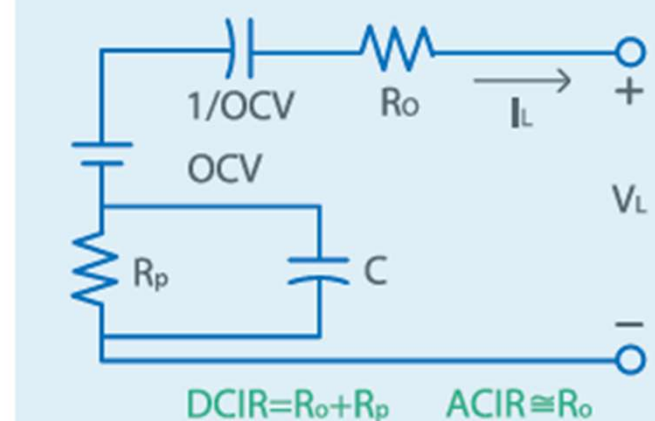

Li-ion battery Equivalent Circuit Model

# 1. Test requirements background

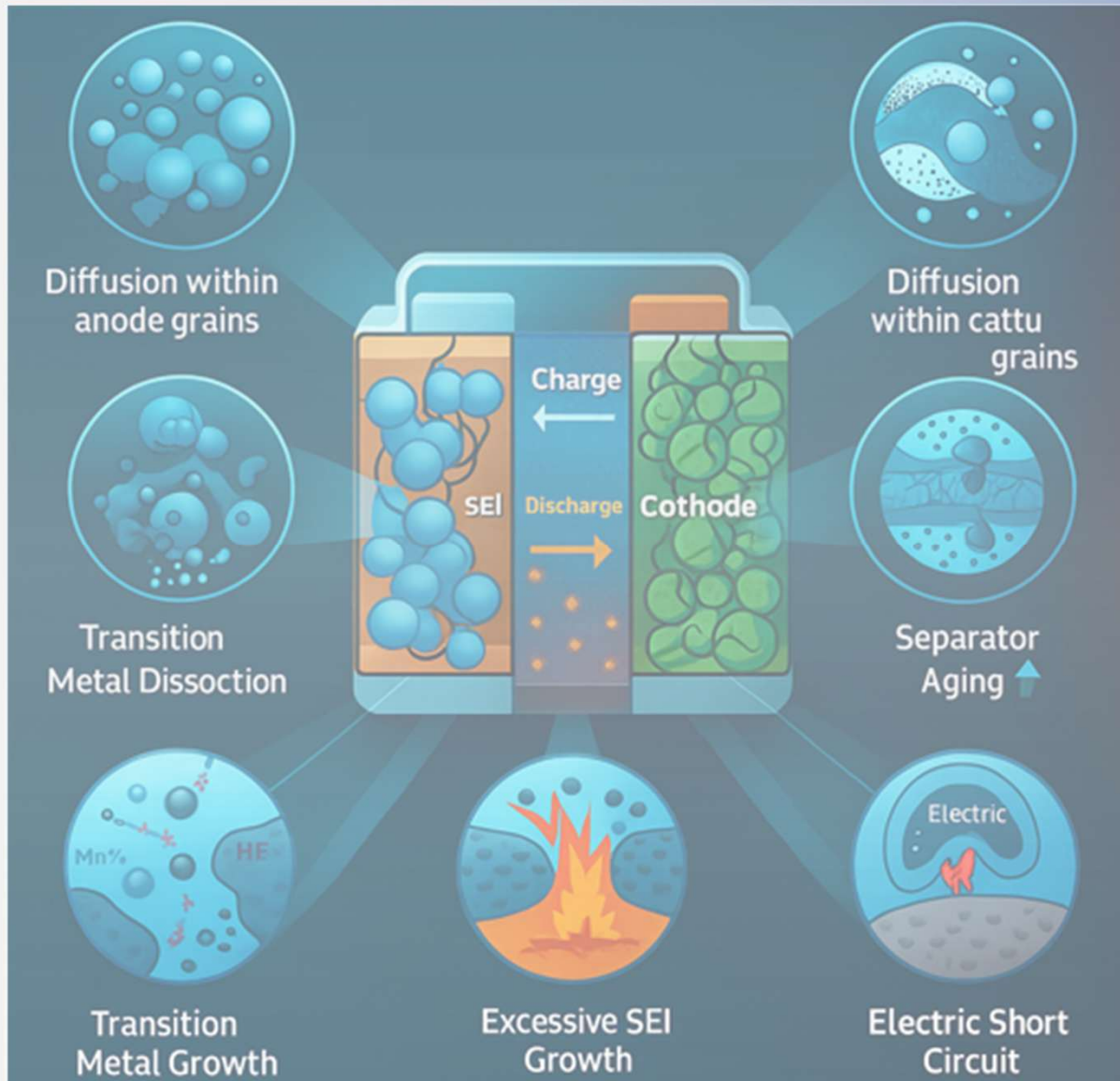

## Need for earlier and more accurate diagnostics

High cost of quality failures and long testing cycles demand faster insights.

## Mechanism analysis

The battery industry is shifting toward mechanism-based testing strategies.

## Degradation analysis

Customer expectations are evolving from simply "capacity / lifetime" toward "predictive diagnostics and degradation insight."



# 1. Cell resistance measurement methods

## Cell resistance measurement methods:

### DCIR (Ohmic resistance).

Measure resistance by applying current pulses

### ACIR (frequency dependent)

Measure resistance by applying 1 kHz AC signal

- \* Fast

- \* Production environments

Not complete picture of cell internal behavior  
(due to minimal polarization).

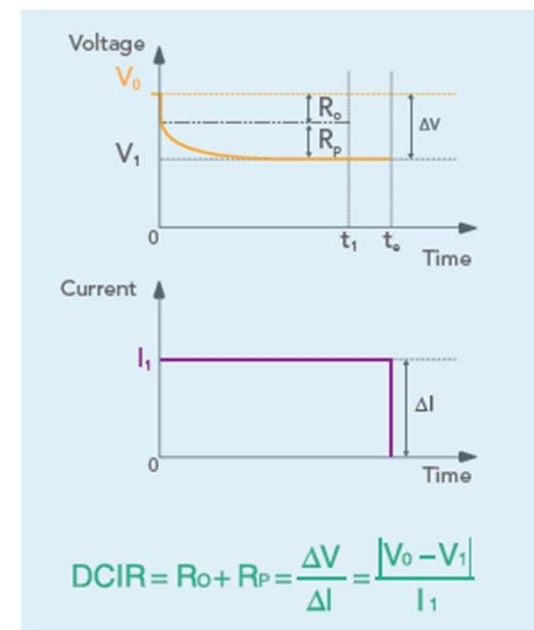

DCIR Test (1)

## EIS (Electrochemical Impedance Spectroscopy)

Measure resistance by applying a range of frequencies (slower than ACIR).  
By EIS we capture how the cell responds to an AC signal across a range of frequencies.

Gives us a much better understanding of an electrochemical system (cell) than a simple resistance measurement (DCIR). Basically, to analyze the internal condition of batteries without opening them.

# 1. Cell resistance measurement methods

- Slow(er) than DCIR & ACIR
- R&D (also in production more frequently)
- Complete picture of cell internal behavior

# 1 . What is EIS?

EIS (Electrochemical Impedance Spectroscopy) provides insight into battery cell impedance over a wide frequency range by using specialized equipment.

EIS gives the best picture of cell impedance and possible issues however due to the multiple frequencies this cost more time than with single 1 kHz frequency.

# 1. What is EIS –three components?

**High frequency intercept (Z-axis):** represents the equivalent series resistance (RESR) including electrolyte resistance, separator and current collectors (contact resistance)

- \* T low ->  $R_{in}$  (internal resistance) up
- \* SOC ->  $R_{in}$ , strong dependent on SOC (%)
- \* Cell aging ->  $R_{in}$  up (cause thickening SEI Solid Electrolyte interface barrier (on anode surface)).

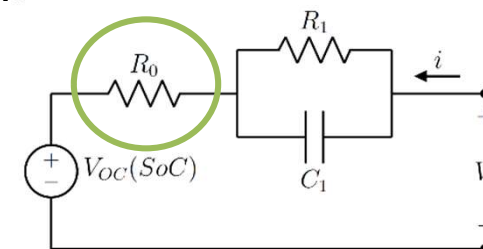

**Semicircle(s):** the diameter represents charge-transfer resistance (RCT) at the electrode/electrolyte interface and SEI resistance.

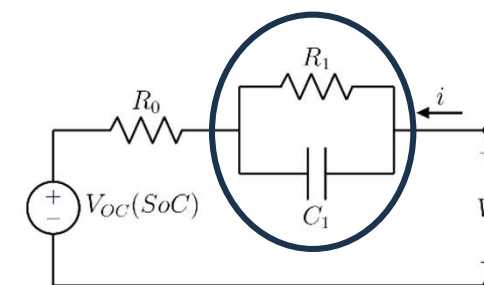

**Low-frequency slope:** A 45-degree slope indicates “Warburg impedance” associated with diffusion of ions into the electrode.



# 1. What is EIS?

## Applications of EIS

- **Battery performance analysis**  
Defines performance limits of the product  
Supports battery development and improvements
- **Aging Modeling**  
Battery State of Function (SOF) Estimation  
Battery State of Health (SOH) Estimation
- **Fault Diagnosis**
- **Fast quality screening and battery matching**

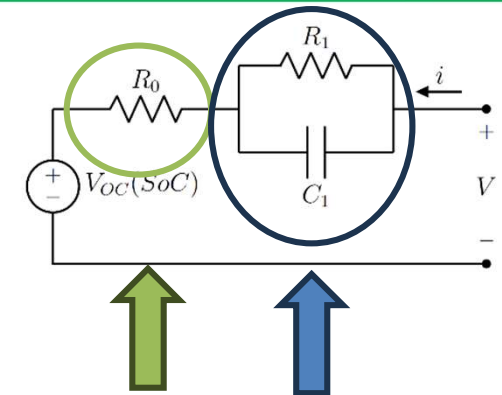
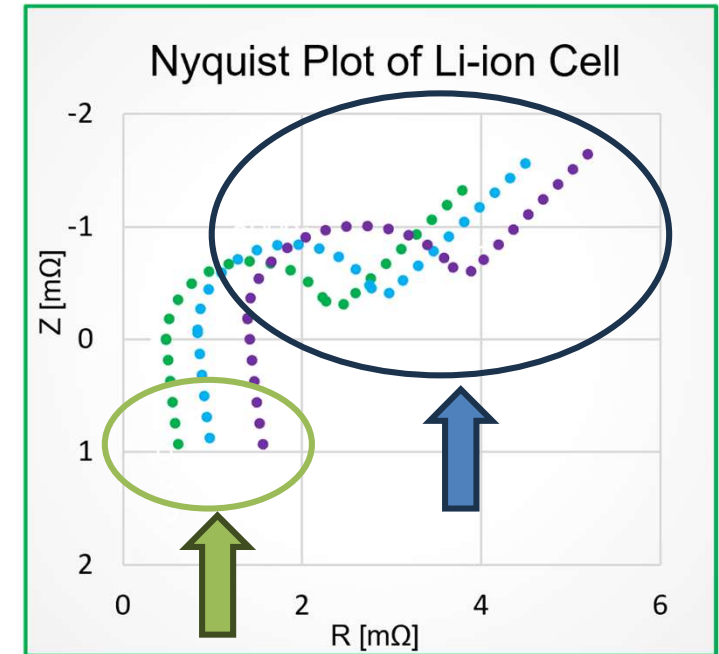

# 1 . Why use EIS?

## Evaluating Battery Health:

The health of a lithium-ion battery can be assessed using EIS, particularly through the charge-transfer resistance ( $R_{ct}$ ) in the mid-frequency region. If the battery is damaged due to long-term use or abuse, the  $R_{ct}$  value may increase, indicating reduced charge-transfer efficiency.

## Analyzing Charge/Discharge Behavior:

The diffusion impedance in the low-frequency region corresponds to the lithium-ion diffusion process within the electrodes, which is critical for evaluating the battery's charge and discharge rate capability. If the diffusion impedance increases, it indicates slower lithium-ion diffusion, which negatively affects battery performance, especially in high-power applications.

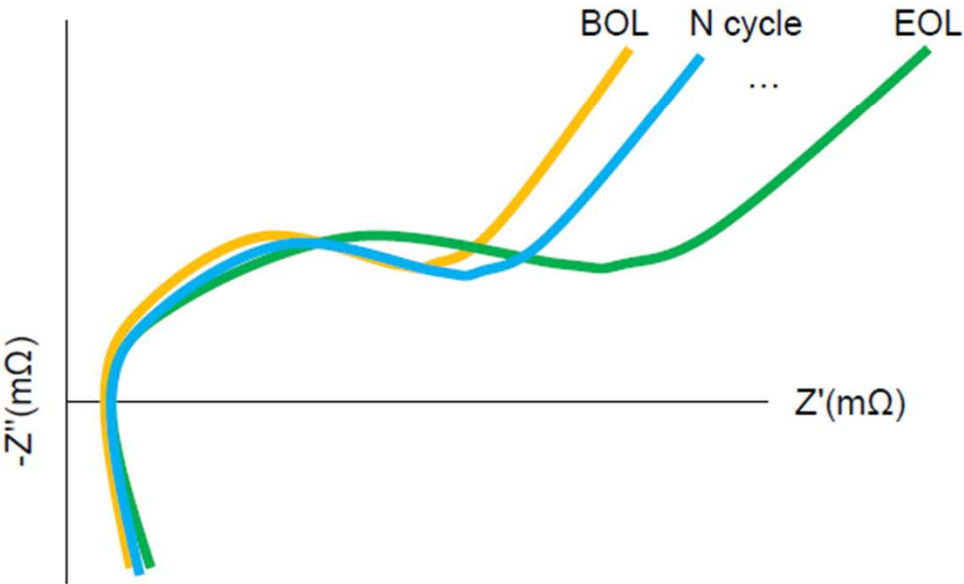

Nyquist Plot

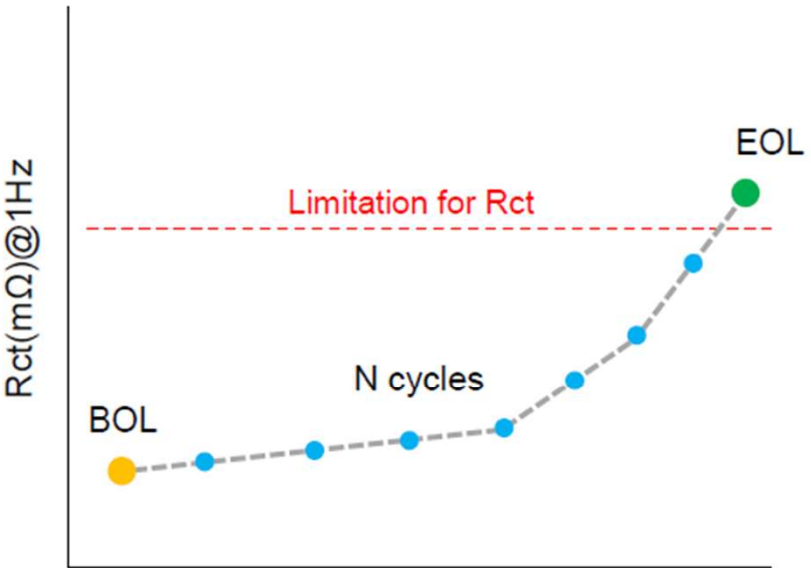

Cycle Number

$R_{ct}$  vs Cycles

## 2. Practical challenges of EIS testing

## 2. Practical challenges of EIS testing

### Challenges of Implementing EIS in Performance Testing EIS

#### 1. Difficulties in Low-Impedance Measurement

Large-format cells exhibit **very low impedance**; detecting characteristic changes requires **extremely high resolution**.

#### 2. Complexity of Station-to-Station Testing

Cells must be repeatedly transferred between charge/discharge testers and EIS instruments, leading to **operational complexity and data management issues**.

#### 3. Limited Scalability Across Channels

**EIS equipment is costly**, making full-channel implementation in performance testing difficult.

#### Traditional Multi-station measurement EIS process

CHG & DCH Tester with chamber

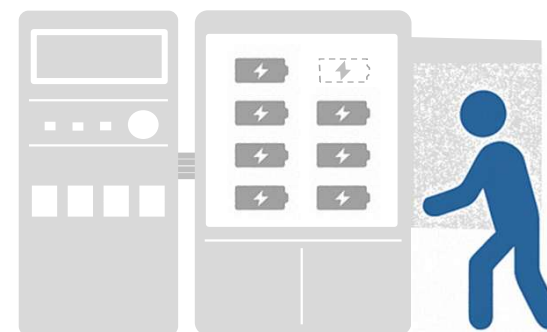

EIS Meter



### 3. Chroma EIS Solution Features

### 3. Chroma EIS Solution Features



#### Stable Ultra-Low Impedance Measurement & Efficient Multi-Channel EIS Solution Battery Impedance Analyzer with Auto-Switching Supports Multi-Channel Testing

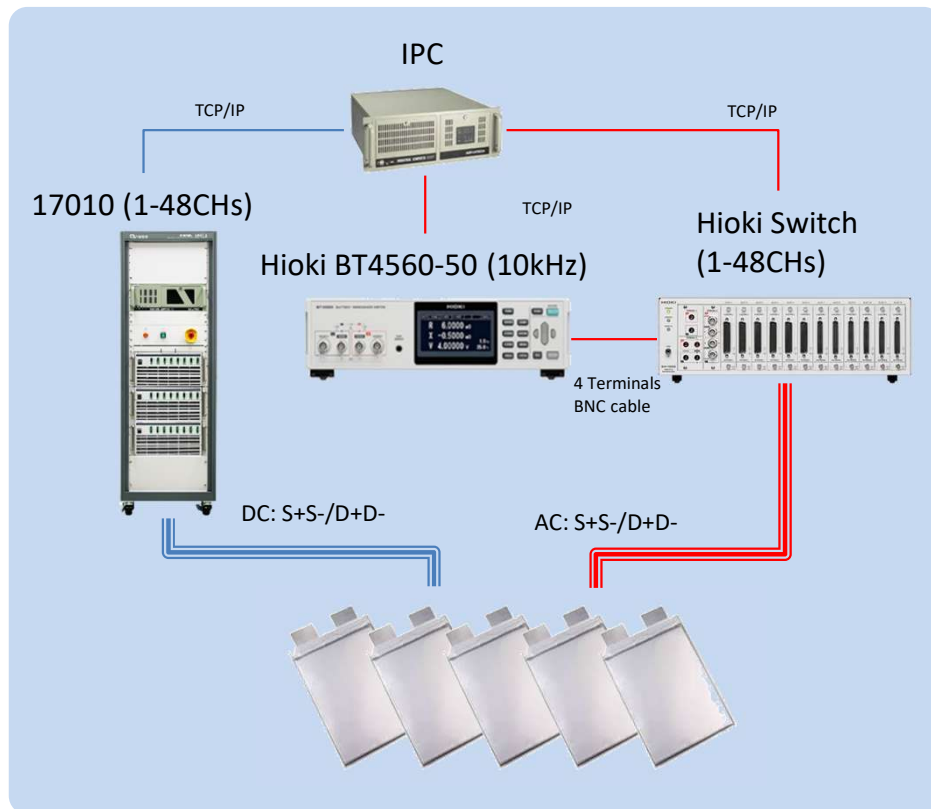

#### Chroma One-stop test solution

CHG & DCH Tester + EIS meter with chamber

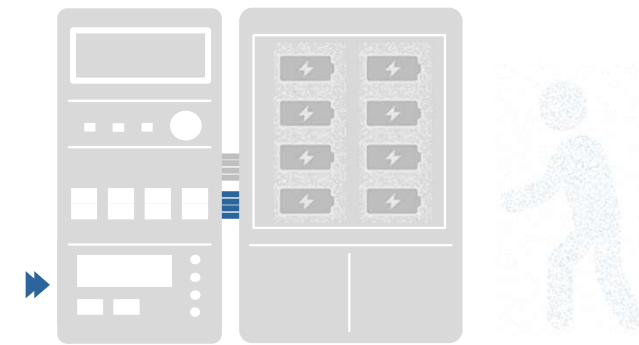

Automatic 1 to many

EIS integration device for 17010x system

- Battery Impedance Meter [Hioki BT4560-50(10 mHz- 1050 Hz)]  
Battery Impedance Meter [Hioki BT4560-60(10 mHz -10kHz)]
- Switch [Hioki SW1001+SW9002] (Max18ch)  
Switch [Hioki SW1002+SW9002] (Max 72ch)

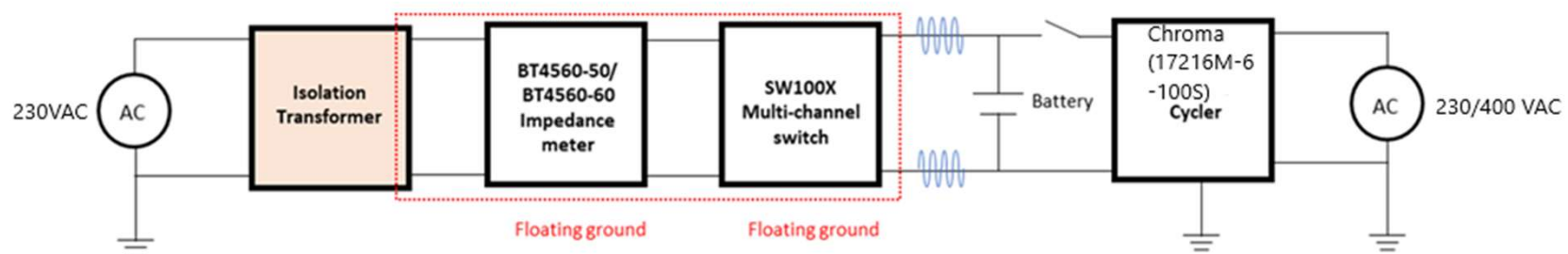

### 3. Chroma EIS Solution Features



#### Hioki BT4560-50 Accuracy Specifications : ( Frequency range **10kHz-10mHz** )

##### Impedance measurement accuracy (α is as shown in the table below.)

- 3 mΩ range (0.01 Hz to 100 Hz), 10 mΩ range, 100 mΩ range

$$R \text{ accuracy} = \pm (0.004 |R| + 0.0017 |X|) [m\Omega] \pm \alpha$$

$$X \text{ accuracy} = \pm (0.004 |X| + 0.0017 |R|) [m\Omega] \pm \alpha$$

(The units of R and X are [mΩ]. α is as shown in the table below.)

$$Z \text{ accuracy} = \pm 0.4\% \text{ rdg.} \pm \alpha (|\sin\theta| + |\cos\theta|)$$

$$\theta \text{ accuracy} = \pm 0.1^\circ \pm 57.3 \frac{\alpha}{Z} (|\sin\theta| + |\cos\theta|)$$

- 3 mΩ range (110 Hz to 1050 Hz)

$$R \text{ accuracy} = \pm (0.004 |R| + 0.0052 |X|) [m\Omega] \pm \alpha$$

$$X \text{ accuracy} = \pm (0.004 |X| + 0.0052 |R|) [m\Omega] \pm \alpha$$

(The units of R and X are [mΩ]. α is as shown in the table below.)

$$Z \text{ accuracy} = \pm 0.4\% \text{ rdg.} \pm \alpha (|\sin\theta| + |\cos\theta|)$$

$$\theta \text{ accuracy} = \pm 0.3^\circ \pm 57.3 \frac{\alpha}{Z} (|\sin\theta| + |\cos\theta|)$$

	Sampling speed	3 mΩ range	10 mΩ range	100 mΩ range
α	FAST	25 dgt.	60 dgt.	60 dgt.
	MED	15 dgt.	30 dgt.	30 dgt.
	SLOW	8 dgt.	15 dgt.	15 dgt.
Temperature coefficient	R: ± R accuracy × 0.1 / °C; X: ± X accuracy × 0.1 / °C; Z: ± Z accuracy × 0.1 / °C; θ: ± θ accuracy × 0.1 / °C (applied in the ranges of 0°C to 18°C and 28°C to 40°C)			

BT4560 basic performance	
Impedance	Maximum resolution: 0.1 μΩ
Voltage range	±5 V, resolution of 10 μV
Measurement current	Max. 1.5 A rms
EIS measurement frequency	10 mHz to 10kHz

Purchase instructions: Hioki BT4560-50 (10kHz)

##### Effect on accuracy of using the instrument with the SW9002<sup>1</sup>

BT4560 (connected via L2004)			
Range	Effect		Conditions, remarks
	Frequency range 0.1 Hz to 100 Hz	Frequency range 110 Hz to 1050 Hz	
3 mΩ R	±0.05% f.s.	±0.1% f.s.	-
3 mΩ X	±0.1% f.s.	±1.0% f.s.	-
10 mΩ R	±0.015% f.s.	±0.03% f.s.	-
10 mΩ X	±0.03% f.s.	±0.3% f.s.	-
100 mΩ R	±0.01% f.s.	±0.01% f.s.	-
100 mΩ X	±0.015% f.s.	±0.03% f.s.	-

# 3. Chroma EIS Solution Features

## Benefits of a one-stop solution

- 1. Greatly reduce manpower & improve efficiency** - one-stop testing, DC, AC testing and ambient temperature control are all programmable by the system, **automated testing, merged data recording**, reducing the burden of experimental manpower and improving efficiency
- 2. Reduce experimental variables** - no need for repeated wiring, eliminate **contact point changes** and **temperature changes** caused by battery removal, control variables to ensure data reliability and reproducibility
- 3. Ultra-low impedance measurement technology** - through high-precision micro-voltage measurement technology and magnetic coupling interference reduction technology, the **measurement resolution can reach  $0.1\mu\Omega$**
- 4. Lowers the barrier for integrating EIS into multi-channel performance testing**

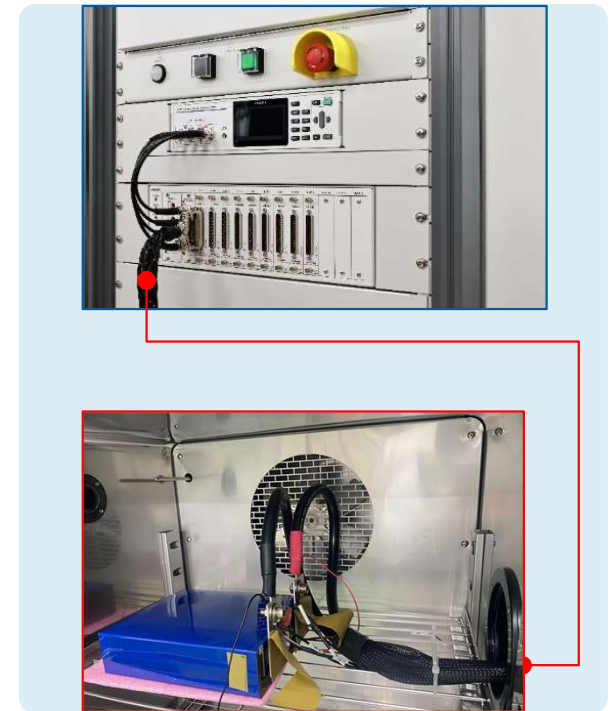

## 4. Function Usage Introduction

## 4. Function Usage Introduction

### Execution Process

#### Recipe Edit

- Battery LEx New Step (AC Impedance step)

#### Wiring and Zero Adjustment

#### Executor

#### Report

# 4. Function Usage Introduction

## Recipe Editor\_ AC Impedance step

General Protection

St...	Setting								Cut-off								Sampling							
	Mode	I(A)	V(V)	P(W)	R( $\Omega$ )	T( $^{\circ}$ C)	Ra...	...	I(A)	V(V)	P(W)	Q(...)	E(...)	Q(%)	T1(...)	...	Time(s)	...	...	Time(s)	$\Delta$ I(A)	$\Delta$ V(V)	$\Delta$ Q...	$\Delta$ E(...)
1	AC Impedance	--	--	--	--	--	Auto	<input type="checkbox"/>	--	--	--	--	--	--	--	(..)	--	--	F(x)	--	--	--	--	--

- CP-CV Discharge
- CR Discharge
- CV Discharge
- Super CC Discharge
- Super CP Discharge
- Rest
- Common Rest
- Chamber Control
- Waveform I
- Waveform P
- Ripple
- Chamber Server
- IMMR Chamber Control
- EDLC IEC 62391
- AC Impedance

### AC Impedance Measurement

Meter : BT4560-50 Estimated Time 05:50 (mm:ss)

Meas. Func.	Meas. Range	Z Meas. Speed			V Meas. Speed
		0.01Hz~66Hz	67Hz~250Hz	260Hz~10kHz	
R, X, V	3m $\Omega$	MED(2 waves)	MED(8 waves)	MED(32 waves)	MED

Multi Freq.  Single Freq. ⓘ

Meas. Start Freq.(Hz)	Meas. End Freq.(Hz)	Point Mode	Meas. Point
10000.00	0.01	Log. Point	7

Scanning frequency points ⓘ

Point Num.	Frequency	Duplicate
1	10000	
2	1000	
3	100	
4	10	
5	1	
6	0.1	
7	0.01	

Step

## 4. Function Usage Introduction



### AC Impedance step \_ Setting Instructions

I. Meas. Function	II. Impedance Meas. Range	III. Z Meas. Speed		
		0.10Hz~66Hz	67Hz~250Hz	260Hz~10kHz
R, X, V (Default)	100.000mΩ	FAST(1 wave)	FAST(2 waves)	FAST(8 waves)
Z, θ, V	10.0000mΩ	MED(2 waves) (Default)	MED(8 waves) (Default)	MED(32 waves) (Default)
R, X	3.0000mΩ (Default)	SLOW(8 waves)	SLOW(32 waves)	SLOW(128 waves)
Z, θ				
IV. V Meas. Speed	V. Meas. Start Freq.	VI. Meas. End Freq.	VII. Point Mode	VIII. Meas. Point
MED (Default)	0.01Hz to 10000.00Hz	0.01Hz to 10000.00Hz , (Single Freq is blank)	Log. Point (Default)	
FAST			AVG. point	1 to 1000
SLOW				

# 4. Function Usage Introduction



## AC Impedance step \_ Setting Instructions

AC Impedance Measurement

Meter : BT4560-50 Estimated Time 01:00 (mm:ss)

Meas. Func.	Meas. Range	Z Meas. Speed			V Meas. Speed
		0.01Hz~66Hz	67Hz~250Hz	260Hz~10kHz	
R, X, V	3mΩ	MED(2 waves)	MED(8 waves)	MED(32 waves)	MED

Multi Freq.  Single Freq. ⓘ

Meas. Start Freq.(Hz)	Meas. End Freq.(Hz)	Point Mode	Meas. Point
10000	0.1	Log. Point	11

Scanning frequency points ⓘ

Point Num.	Frequency	Duplicate
1	10000	
2	3160	
3	1000	
4	310	
5	100	
6	32	
7	10	
8	3.2	
9	1	
10	0.32	
11	0.1	

Buttons: Advance Settings, OK, Cancel

	e.g.1	e.g. 2
Point Mode	<b>Log. Point</b>	<b>AVG. Point</b>
Start Frequency	10Hz	10Hz
End Frequency	1Hz	1Hz
Meas. Point	11	11
Measuring point		
Point 1	<b>10000Hz</b>	<b>10000.00Hz</b>
Point 2	3160Hz	9000Hz
Point 3	1000Hz	8000Hz
Point 4	310Hz	7000Hz
Point 5	100Hz	6000Hz
Point 6	32Hz	5000Hz
Point 7	10.0Hz	4000Hz
Point 8	3.2Hz	3000Hz
Point 9	1Hz	2000Hz
Point 10	0.32Hz	1000Hz
Point 11	<b>0.1Hz</b>	<b>0.1Hz</b>

# 4. Function Usage Introduction

## AC Impedance step \_ Setting Instructions

AC Impedance Measurement

Meter : BT4560-50

Estimated Time 03:41 (mm:ss)

Meas. Func.	Meas. Range	Z Meas. Speed			V Meas. Speed
		0.01Hz~66Hz	67Hz~250Hz	260Hz~10kHz	
R, X, V	3mΩ	MED(2 waves)	MED(8 waves)	MED(32 waves)	MED

Multi Freq.  Single Freq.

Meas. Start Freq.(Hz)	Meas. End Freq.(Hz)	Point Mode	Meas. Point
10000	0.1	Log. Point	51

Scanning frequency points

Point Num.	Frequency	Duplicate
1	10000	
2	7940	
3	6300	
4	5010	
5	3980	
6	3160	
7	2510	
8	1990	
9	1580	
10	1250	
11	990	

Advance Settings OK Cancel

Estimating measurement time based on parameters

Single frequency measurement mode

# 4. Function Usage Introduction



## Support Switch channel Zero Adjustment:

Manual Zero Adjustment can be performed in the channel standby state. Usually, a channel Zero Adjustment is performed when the wiring changes to offset the measurement error caused by different wiring paths.

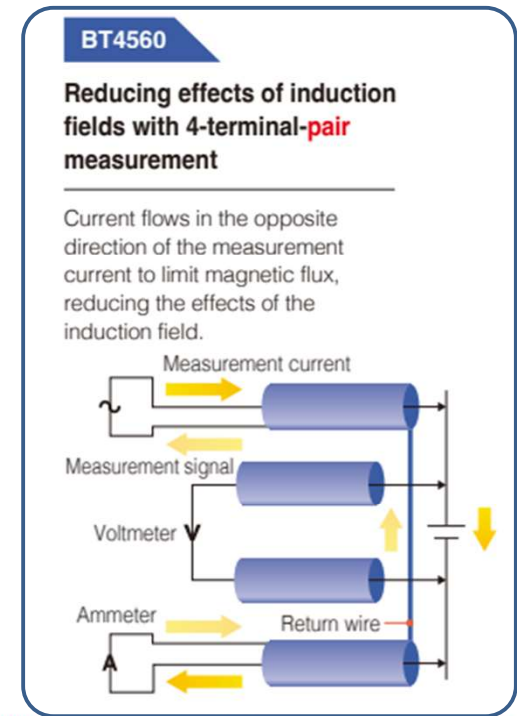
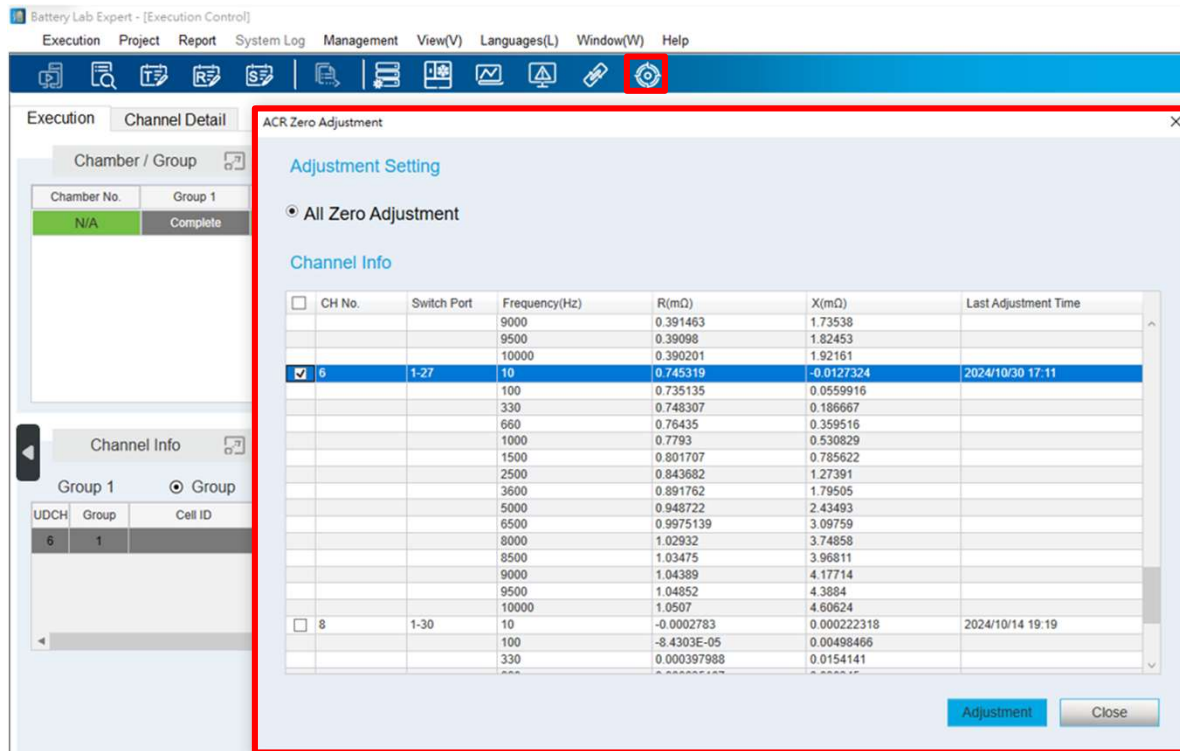
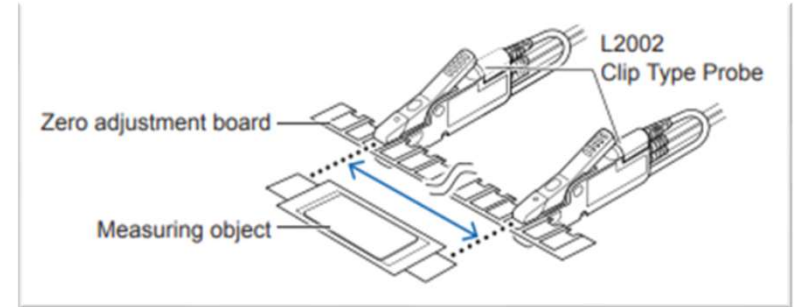

# Zero adjustment hardware configuration connection

## BNC Connections

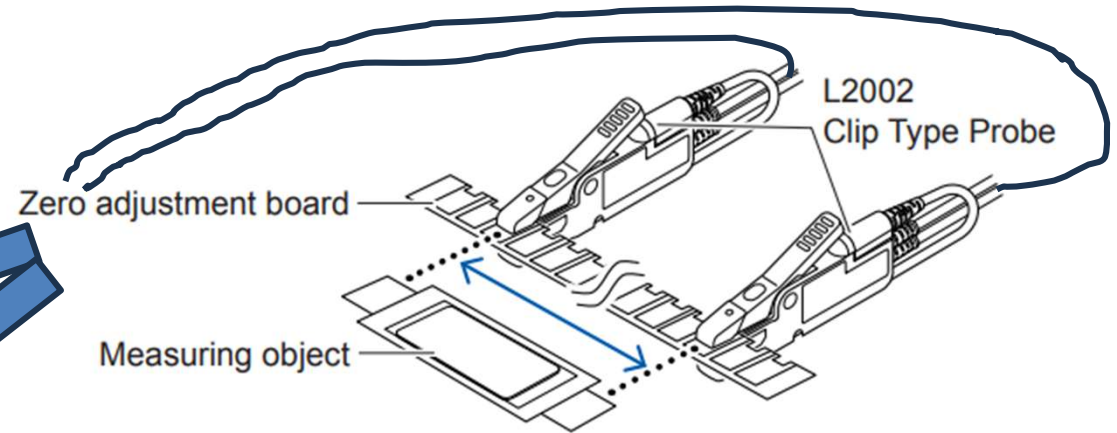
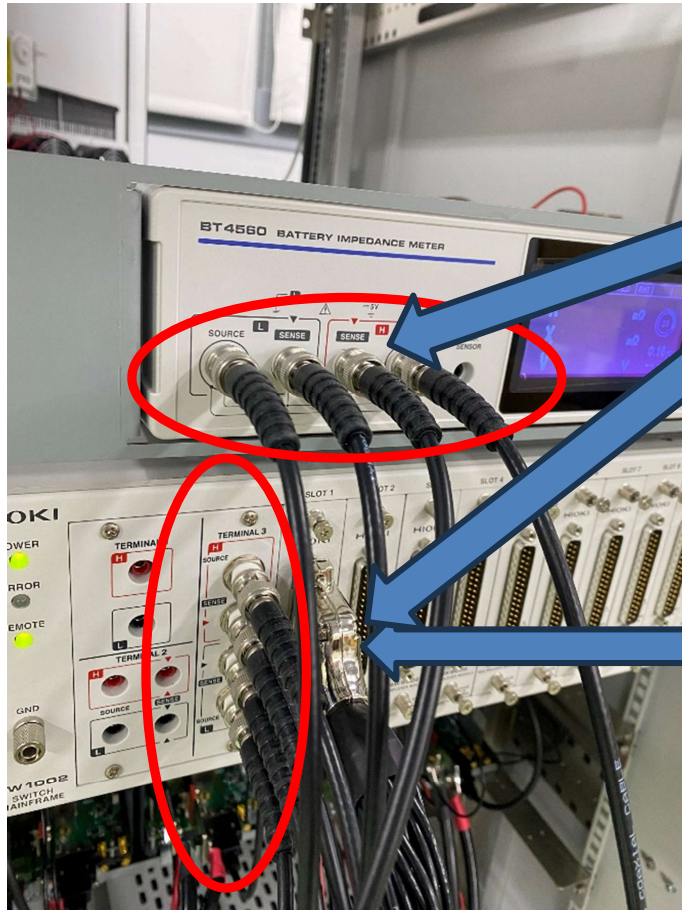

If you have more than one EIS channel you need to use SW1001 or SW1002. The cables connected to it can not be connected to the Hioki zero adjustment board. Only when you have BT4560-50/60 as single channel EIS you can use it by using the probes (see picture).

# Zero adjustment fixtures examples

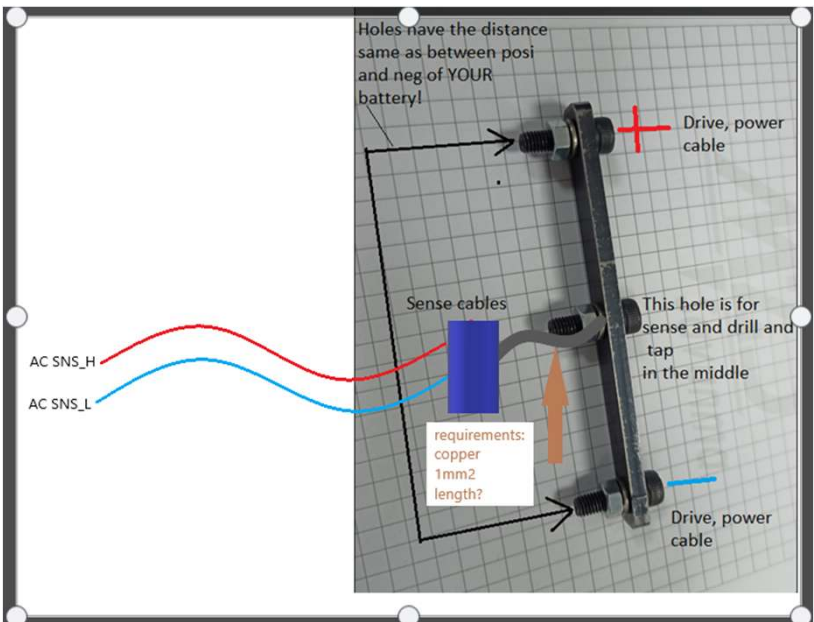

Here you see the AC senses are connected. A third wire is connecting the senses to the mid-point of the zeroing fixture (AC drive cable and return cable still need to be connected).

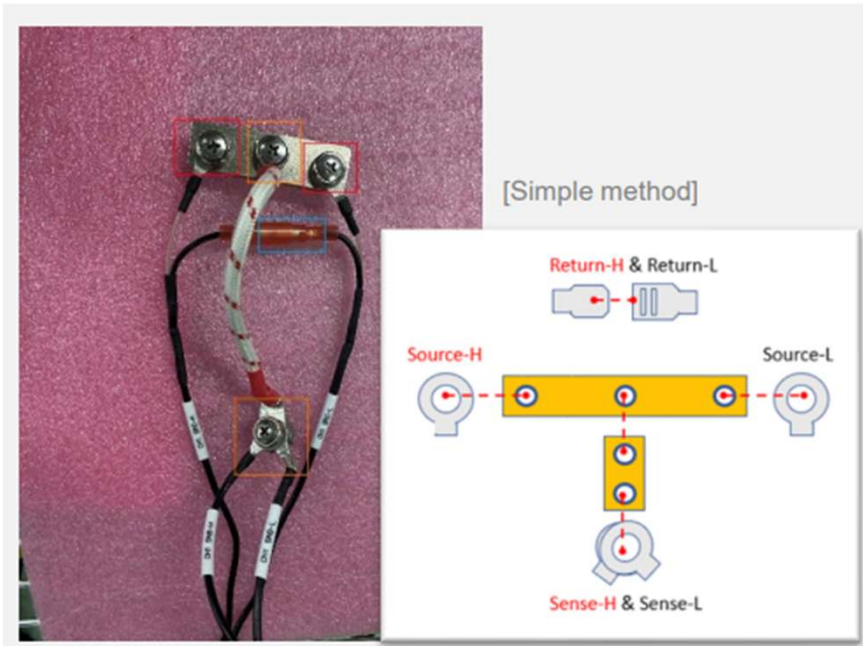

Here you see all wires connected AC drive+ and AC drive- (on each side of fixture) AC sense+ and AC sense- (by the white/red wire) Return cable

Do not cross AC (Hioki) and DC (Chroma) cables.

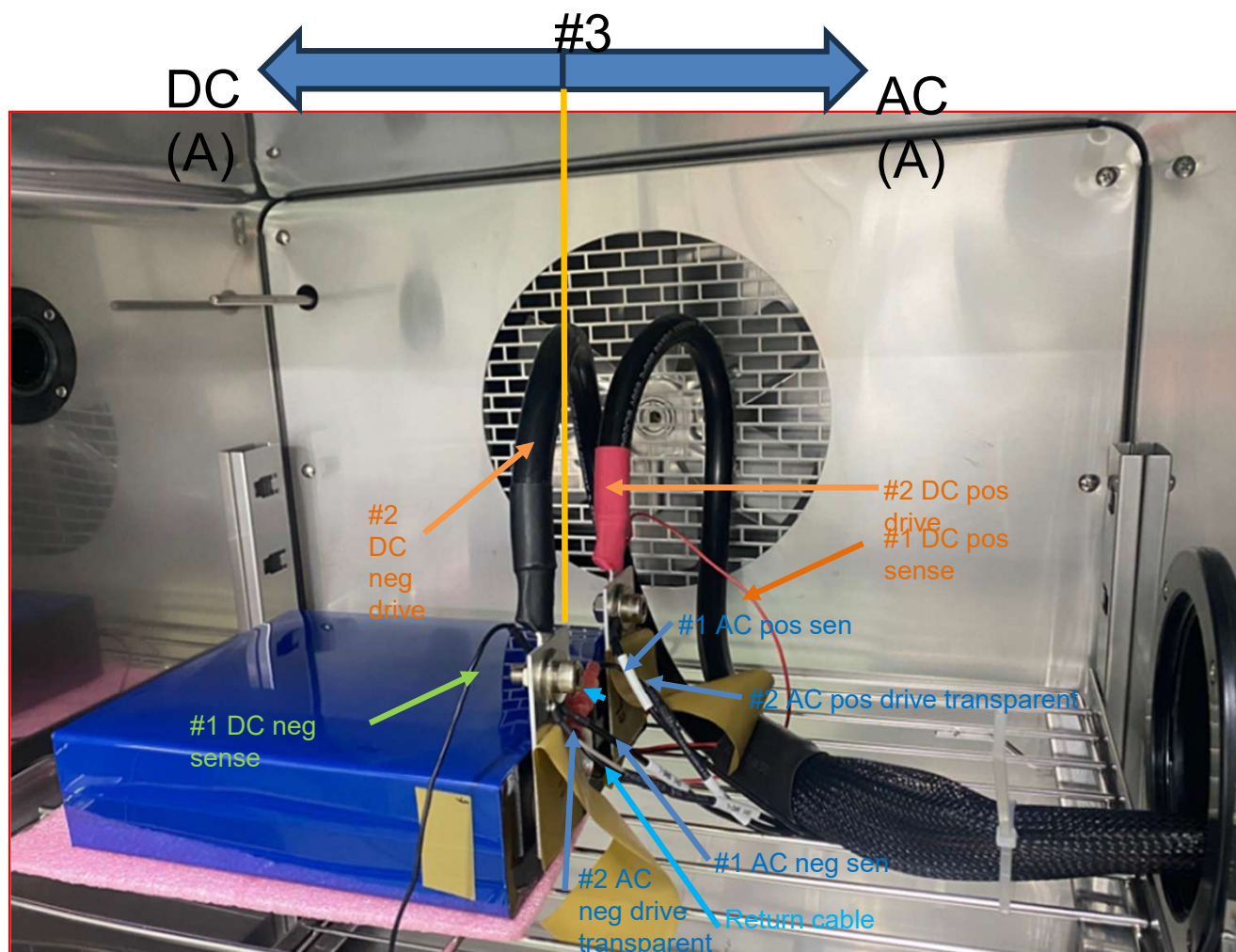

On the terminals metal strips are mounted.

Always connect the senses firstly #1 and on top of it the corresponding drive #2. Always keep AC and DC cables separated!

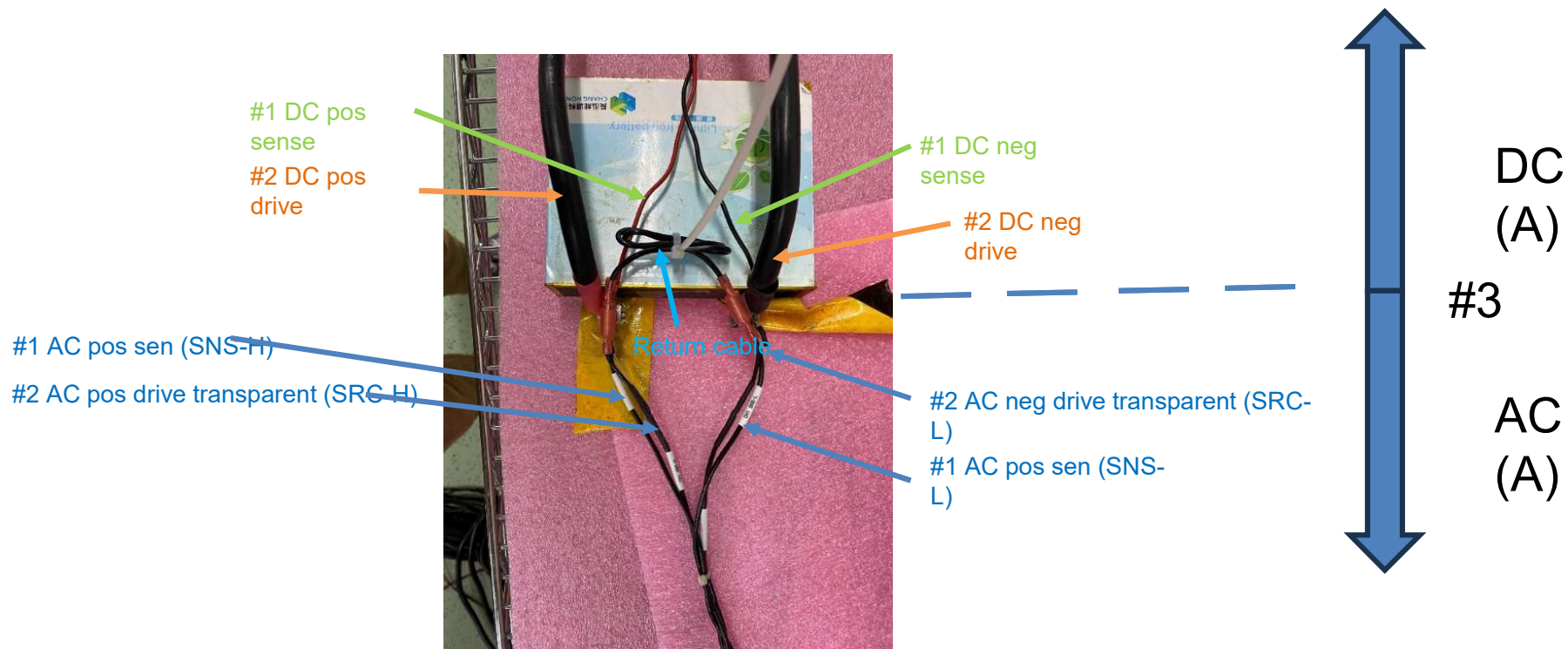

Do not cross AC (Hioki) and DC (Chroma) cables.

# 4. Function Usage Introduction



## Executor\_ Automatic channel sequencing

The screenshot displays the Chroma software interface for channel sequencing. It includes a top toolbar with various icons, a main navigation bar with 'Execution' and 'Channel Detail' tabs, and several control panels. The 'Chamber / Group' panel shows a table with columns for Chamber No., Group 1, and Group 2. The 'Test Control' panel features buttons for Test, Pause, Resume, Stop, Reserve, Skip, and Update, along with an 'OverAll' section. The 'Channel Info' panel shows a table with columns for UDCH, Group, Cell ID, Status, Mode, MR No, SR No, Step No, I(A), V(V), P(W), RLoop(Ω), Act.Exec Time, and Aux T1. A callout box highlights the 'Running' status and 'AC Impedance' mode for a specific channel.

Chamber No.	Group 1	Group 2
N/A	Running	Available

Chamber : N/A / Group :1 / Channel :6

Channel	6	Start Time	2024/11/13 16:34:26
Project	17010-h-6-300s	Execution Time	0:00:10
Test Plan	EIS_10k-1k	Remark	
Operator	fae	Status	Running

Group 1  Group  Chamber  All Channels

UDCH	Group	Cell ID	Status	Mode	MR No	SR No	Step No	I(A)	V(V)	P(W)	RLoop(Ω)	Act.Exec Time	Aux T1
6	1		Running	AC Impedance	1	1	2	0.00000000	0.9426	0.000000	NaN	00:00:00:08	

Running  
Waiting ExtDev

# 4. Function Usage Introduction



## Report \_ Independent AC Impedance Data

Search Data List + 01.2024-11-13 16:43:42 CH6

01.2024-11-13 16:43:42

Step Data P. 1 / 1 Page Count: 500

Cycle	Loop	Sub L2	Sub L1	MR No.	SR No.	Step No.	Step	Step Mode	Date Time	Step Time(s)	Step Time	Status	Voltage(V)	Current(A)	Power(W)	Capacity(Ah)
1	1	1	1	1	1	1	1	REST	11/13/2024 4:43:42 PM	5.000000	00:00:00:05.000	StepFinishByCut_T	0.942556	0.000000	0.000000	0.000000
1	1	1	1	1	1	2	2	AC Impedance	11/13/2024 4:43:47 PM	26.043000	00:00:00:26.043	StepRunning	0.942546	0.000000	0.000000	0.000000
1	1	1	1	1	1	3	3	REST	11/13/2024 4:44:13 PM	2.000000	00:00:00:02.000	StepFinishByCut_T	0.942519	0.000000	0.000000	0.000000
1	1	1	1	1	1	4	4	AC Impedance	11/13/2024 4:44:15 PM	25.341000	00:00:00:25.341	StepRunning	0.942519	0.000000	0.000000	0.000000

Generate

Detail Data P. 1 / 0 Page Count: 500

Cycle	Loop	Sub L2	Sub L1	MR No.	SR No.	Step No.	Step	Step Mode	Date Time	Test Time(s)	Step Time(s)	Status	Voltage(V)	Current(A)	Power(W)	Capacity(Ah)	Energy(Wh)	Total Capacity(Ah)
-------	------	--------	--------	--------	--------	----------	------	-----------	-----------	--------------	--------------	--------	------------	------------	----------	--------------	------------	--------------------

AC Impedance Data P. 1 / 1 Page Count: 500

Cycle	Loop	Sub L2	Sub L1	MR No.	SR No.	Step No.	Step	f(Hz)	Z(m $\Omega$ )	$\theta(^{\circ})$	R(m $\Omega$ )	X(m $\Omega$ )	OCV(V)
1	1	1	1	1	1	2	2	10,000.00	-60,000.0000	-60,000.0000	0.0056	0.0137	0.942542
1	1	1	1	1	1	2	2	7,740.00	-60,000.0000	-60,000.0000	-0.0192	0.0131	0.942548
1	1	1	1	1	1	2	2	5,990.00	-60,000.0000	-60,000.0000	-0.0440	0.0154	0.942540
1	1	1	1	1	1	2	2	4,640.00	-60,000.0000	-60,000.0000	-0.0602	0.0106	0.942539
1	1	1	1	1	1	2	2	3,590.00	-60,000.0000	-60,000.0000	-0.0678	0.0018	0.942550
1	1	1	1	1	1	2	2	2,780.00	-60,000.0000	-60,000.0000	-0.0686	-0.0016	0.942566
1	1	1	1	1	1	2	2	2,150.00	-60,000.0000	-60,000.0000	-0.0669	-0.0039	0.942541
1	1	1	1	1	1	2	2	1,670.00	-60,000.0000	-60,000.0000	-0.0665	-0.0038	0.942562
1	1	1	1	1	1	2	2	1,290.00	-60,000.0000	-60,000.0000	-0.0653	-0.0041	0.942559
1	1	1	1	1	1	2	2	1,000.00	-60,000.0000	-60,000.0000	-0.0644	-0.0044	0.942536
1	1	1	1	1	1	4	4	10,000.00	0.0186	55.3382	-600,000.0000	-600,000.0000	-60,000.000000
1	1	1	1	1	1	4	4	7,740.00	0.0237	145.0822	-600,000.0000	-600,000.0000	-60,000.000000
1	1	1	1	1	1	4	4	5,990.00	0.0466	160.5421	-600,000.0000	-600,000.0000	-60,000.000000
1	1	1	1	1	1	4	4	4,640.00	0.0611	169.9841	-600,000.0000	-600,000.0000	-60,000.000000
1	1	1	1	1	1	4	4	3,590.00	0.0678	178.5827	-600,000.0000	-600,000.0000	-60,000.000000
1	1	1	1	1	1	4	4	2,780.00	0.0687	-178.7867	-600,000.0000	-600,000.0000	-60,000.000000
1	1	1	1	1	1	4	4	2,150.00	0.0668	-176.9290	-600,000.0000	-600,000.0000	-60,000.000000
1	1	1	1	1	1	4	4	1,670.00	0.0669	-176.5096	-600,000.0000	-600,000.0000	-60,000.000000
1	1	1	1	1	1	4	4	1,290.00	0.0653	-176.4429	-600,000.0000	-600,000.0000	-60,000.000000

**R, X, OCV mode**

**Z,  $\theta$  mode**

## 5. Product Specifications

# 5. Product Specifications



## Chroma 17010H + EIS



**10kHz-10mHz** EIS Frequency range

**$\pm (0.4\% |R| + 0.52\% |X|)$**  Impedance MEAS (R) accuracy

**0.1 $\mu\Omega$**  Impedance MEAS resolution

**0-6V** Voltage Range

**$\pm 0.015\%FS$**  V Accuracy

**300A/150A/30A** 3 Ranges

**$\pm 0.05\%FS$**  I Accuracy

**2400A Cont.** max parallel-able current

**75%** Energy Regeneration Eff.

**EIS function (Option)**  
can be integrated into all  
17010 /17010H models



Thank You