

A futuristic cityscape at night, featuring glowing skyscrapers and light trails. The scene is dominated by blue and green hues, with light trails in the foreground suggesting motion and data flow. The background shows a dense urban environment with various building shapes and heights, all illuminated against a dark sky.

Chroma

SOP EIS process

2/2/2026

SOP

EIS process

Chroma ATE Europe BV

Freek Dillingh

01/21/2026 last update 02/02/2026

Chroma
CHROMA ATE EUROPE

Introduction

- The goal is to show how the EIS process needs to be executed.
- Used software Chroma Battery Lex (with zeroing function).
- Used hardware:
 - Chroma 17010 model 17212M-6-100S;
 - Hioki BT4560-50 single channel impedance meter and Hioki SW1002 multichannel switch box.

EIS

EIS (Electrochemical Impedance Spectroscopy) provides insight into battery cell impedance over a wide frequency range by using specialized equipment. EIS gives the best picture of cell impedance and possible issues however due to the multiple frequencies this cost more time than with single 1 kHz frequency.

How is the system connected –block diagram

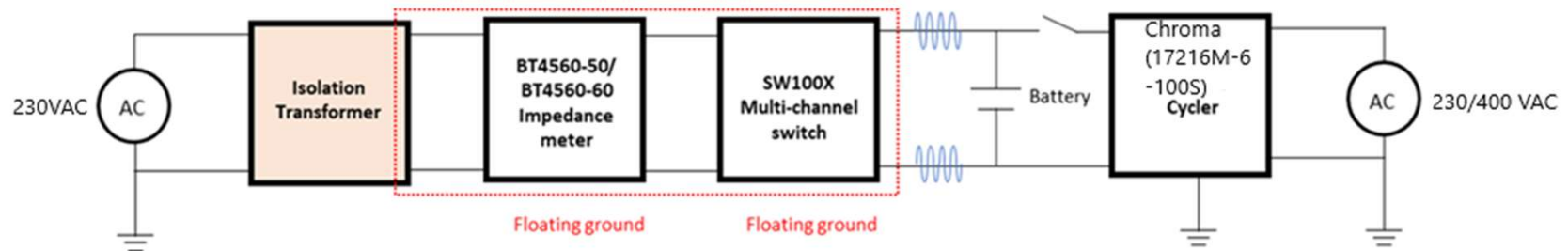

EIS operation process – execution steps

EIS Operation Process

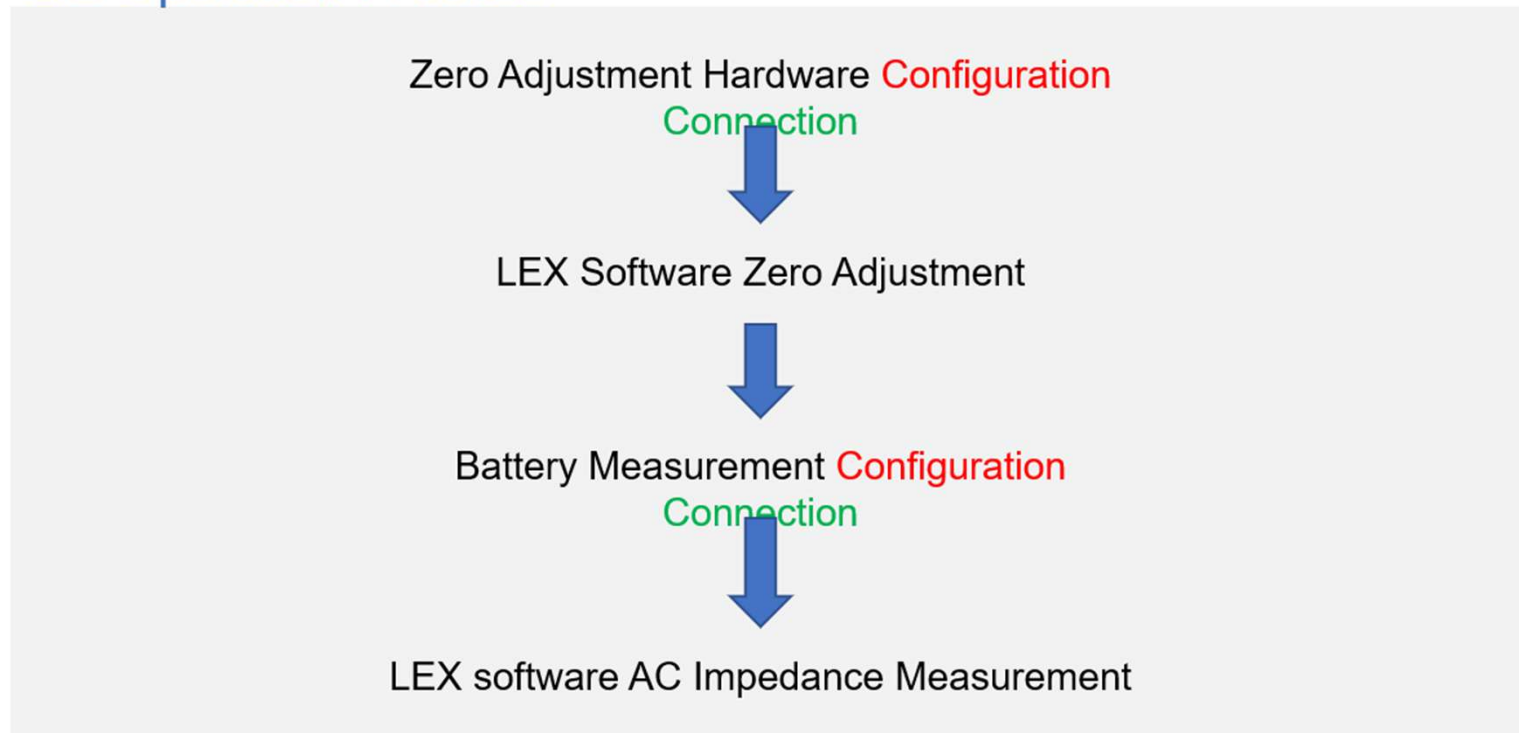

Zero adjustment hardware configuration

- Before performing the real EIS measurements, you must perform a zero adjustment. The main purpose of zero-adjustment is to eliminate EMI Electro Magnetic Interference values in the wiring path. Changes in inductance due to different wiring paths can lead to miscalculations in measurement values.
- When zeroing adjustment is not or not good executed the final EIS results are not reliable.

Zero adjustment hardware configuration connection

BNC Connections

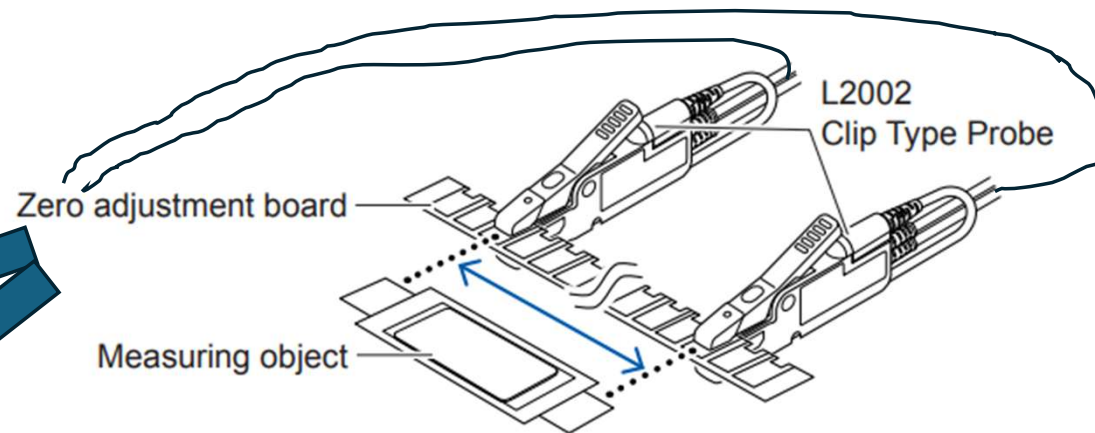
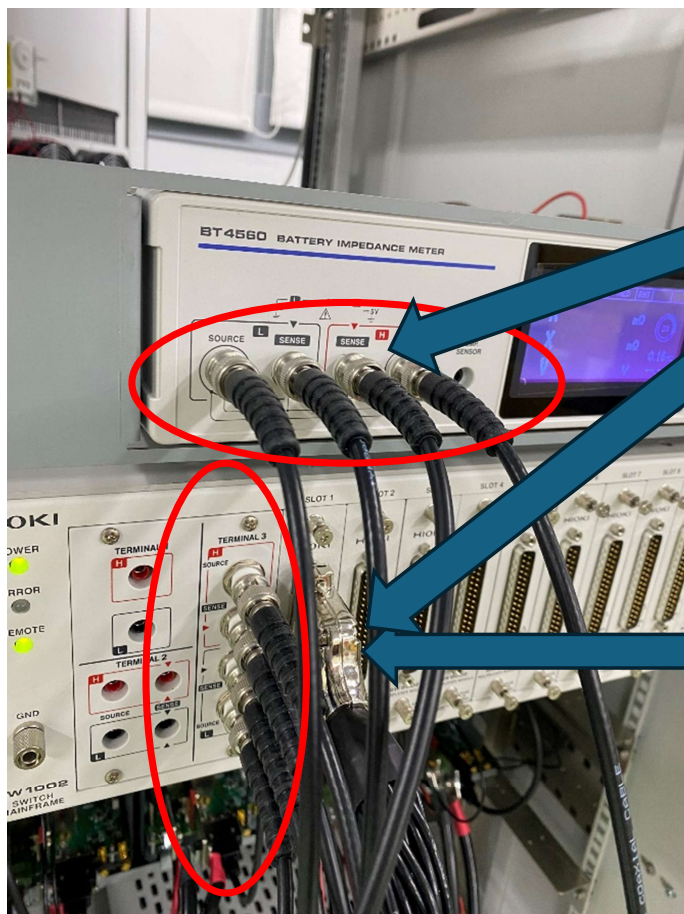

If you have more than one EIS channel you need to use SW1001 or SW1002. The cables connected to it can not be connected to the Hioki zero adjustment board. Only when you have BT4560-50/60 as single channel EIS you can use it by using the probes (see picture).

Zero adjustment hardware configuration connection

Connecting the Calibration Jig and EIS Measurement Cables

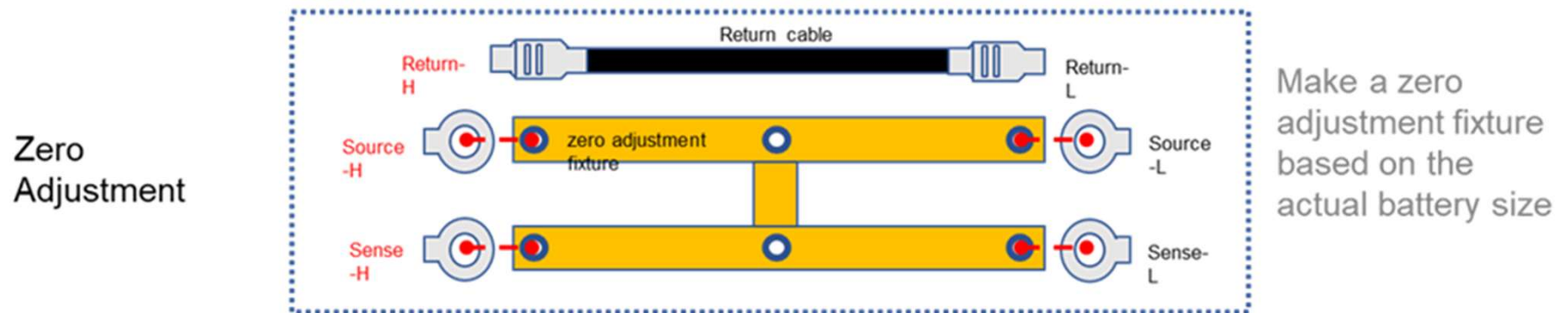

Requirements zero fixture:

- Low resistance conductor i.e., copper;
 - Length adjustment fixture must be roughly same as the pos to neg terminal distance of your cell;
 - The wiring needs to be the shortest path to the battery (4-wires);
 - Zeroing fixture design also considers the shortest path
- (1) Connect ACDrive+ to ACDrive- first (transparent wire color) on each side of the zero fixture;
 - (2) Connect ACSense+ to ACSense- together (e.g. by bolt);
 - (3) Connect (1) and (2) together (single-point connection e.g. by a wire).

Zero adjustment hardware configuration connection

Connecting the Calibration Jig and EIS Measurement Cables

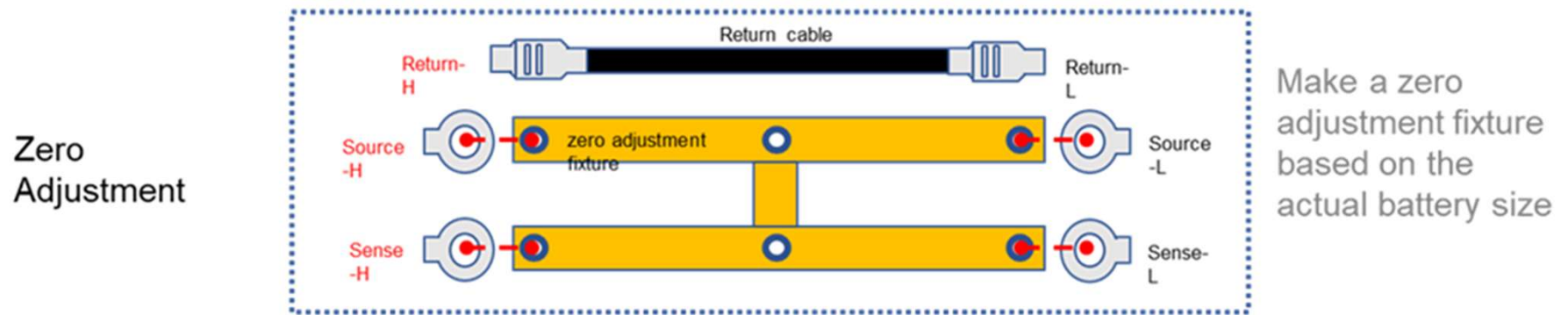

Requirements return cable:

- Low resistance conductor i.e., copper wire;
- Length return cable must be roughly same as the pos to neg terminal distance of your cell;
- Connect the return cable and keep it connected during all the steps;
- Do not move nor touch the return cable anymore

Zero adjustment hardware configuration connection -examples

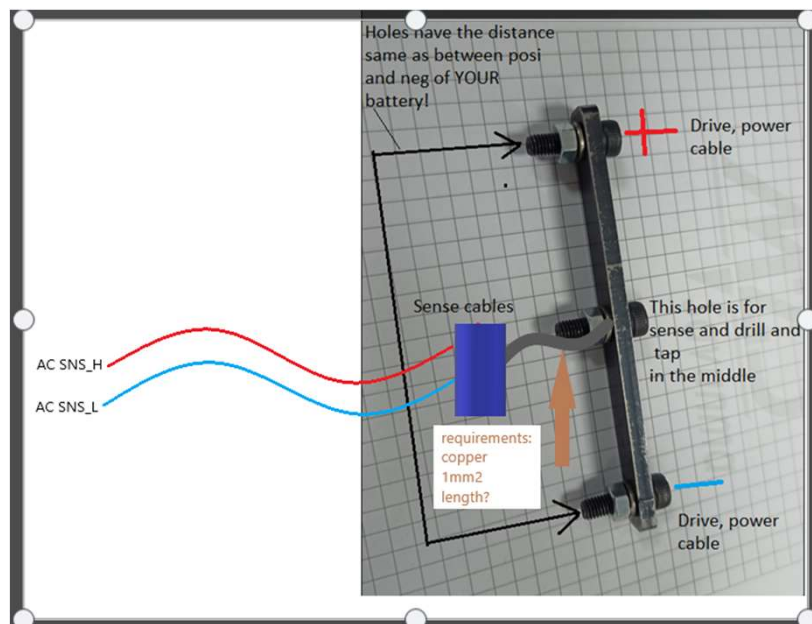

Here you see the AC senses are connected. A third wire is connecting the senses to the mid-point of the zeroing fixture (AC drive cable and return cable still need to be connected).

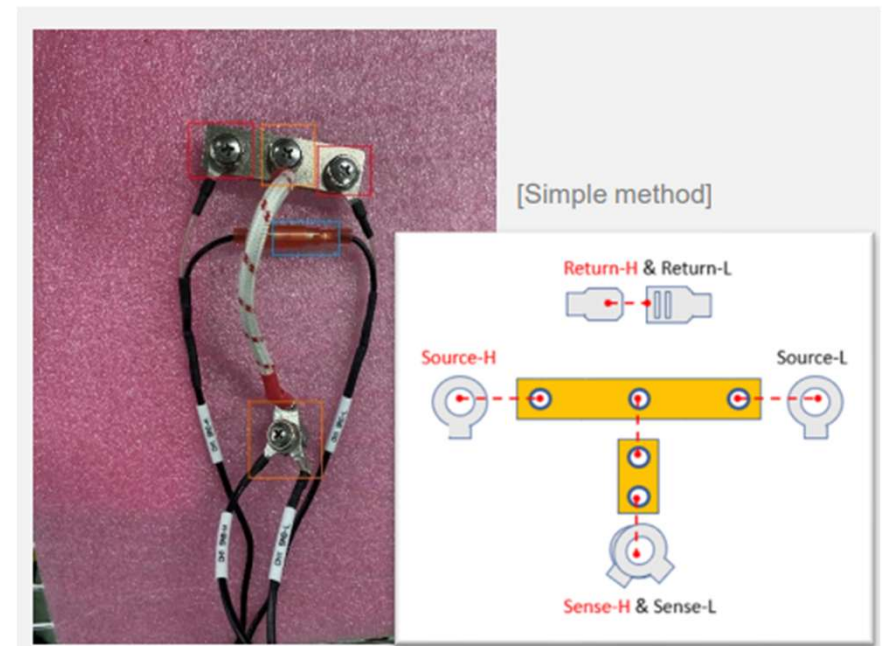

Here you see all wires connected AC drive+ and AC drive- (on each side of fixture) AC sense+ and AC sense- (by the white/red wire) Return cable

Lex software zero adjustment – hwc

Module Information			
Model Name	Channel	Module Name	Specified Index
Hioki BT4560-50	1	1050Hz-10mHz type	1
		NONE	
		10kHz-10mHz type	
		1050Hz-10mHz type	

- The selected Hioki model determines the frequency range (0.01 Hz to 1050 Hz).

Lex software zero adjustment - executor

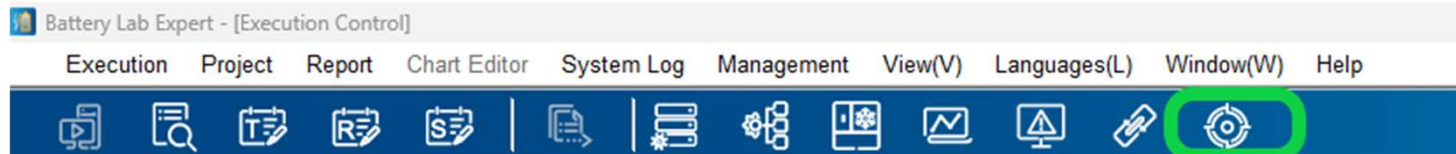

ACR Zero Adjustment

Adjustment Setting

• All Zero Adjustment

Channel Info

<input type="checkbox"/>	CH No.	Switch Port	Frequency(Hz)	R(mΩ)	X(mΩ)	Last Adjustment Time
<input type="checkbox"/>	1	1-1	10	9.200339	0.09212918	2025/06/13 21:00
			100	5.231388	1.864916	
			330	0.1496218	3.290289	
			660	8.655906	1.662641	
			1050	0.7502396	6.981971	
<input type="checkbox"/>	2	1-2	10	--	--	2025/06/13 14:26
			100	--	--	
			330	--	--	
			660	--	--	
			1050	--	--	
<input type="checkbox"/>	3	1-3	10	--	--	--
			100	--	--	
			330	--	--	
			660	--	--	
			1050	--	--	
<input type="checkbox"/>	4	1-4	10	--	--	--
			100	--	--	
			330	--	--	
			660	--	--	
			1050	--	--	

Adjustment Close

After pressing this button the ACR zero adjustment will open.

The zero-frequency range is from 10 Hz to 1050 Hz.

You can adjust per channel. Here only channel 1 has been adjusted.

Lex software zero adjustment - executor why not zero below 10 Hz?

- The electromagnetic interference (EMI) value below 10 Hz is extremely low. Better to say is that low frequency EMI has other specific characteristics than high frequency EMI. To reduce or eliminate EMI filtering, grounding or shielding methods can be used. The zero-adjustment time is shortened by using an arithmetic method. Electromagnetic Interference becomes very low (negligible) at extremely low frequencies. Around Hioki AC cables shielding is used and this becomes more effective for low frequencies. This is meaning zeroing below 10 Hz is not mandatory.

Battery measurement configuration – connection order

Now it is time to remove your zero-fixture and connect your cell (return cable stays connected!). Use following connection and separation principles.

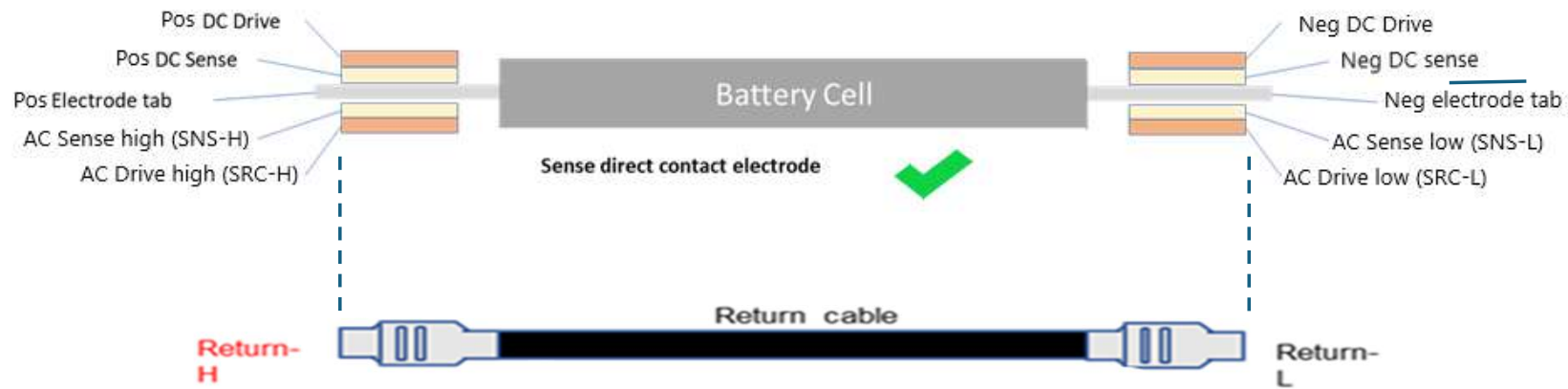

Battery measurement configuration – routing example 1

Do not cross AC (Hioki) and DC (Chroma) cables.

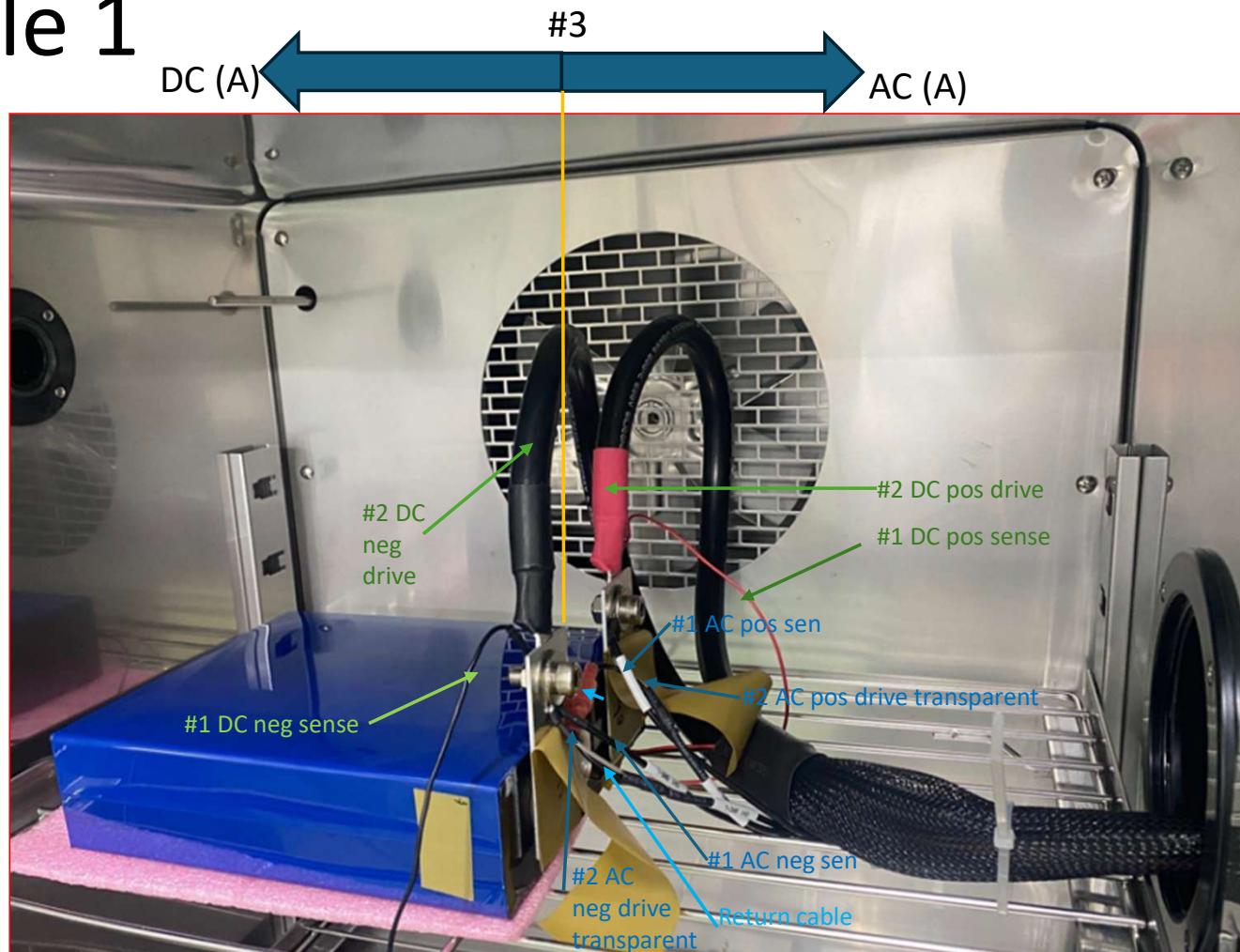

On the terminals metal strips are mounted.

Always connect the senses firstly #1 and on top of it the corresponding drive #2.

Always keep AC and DC cables separated by the tab #3

Battery measurement configuration – routing example 2

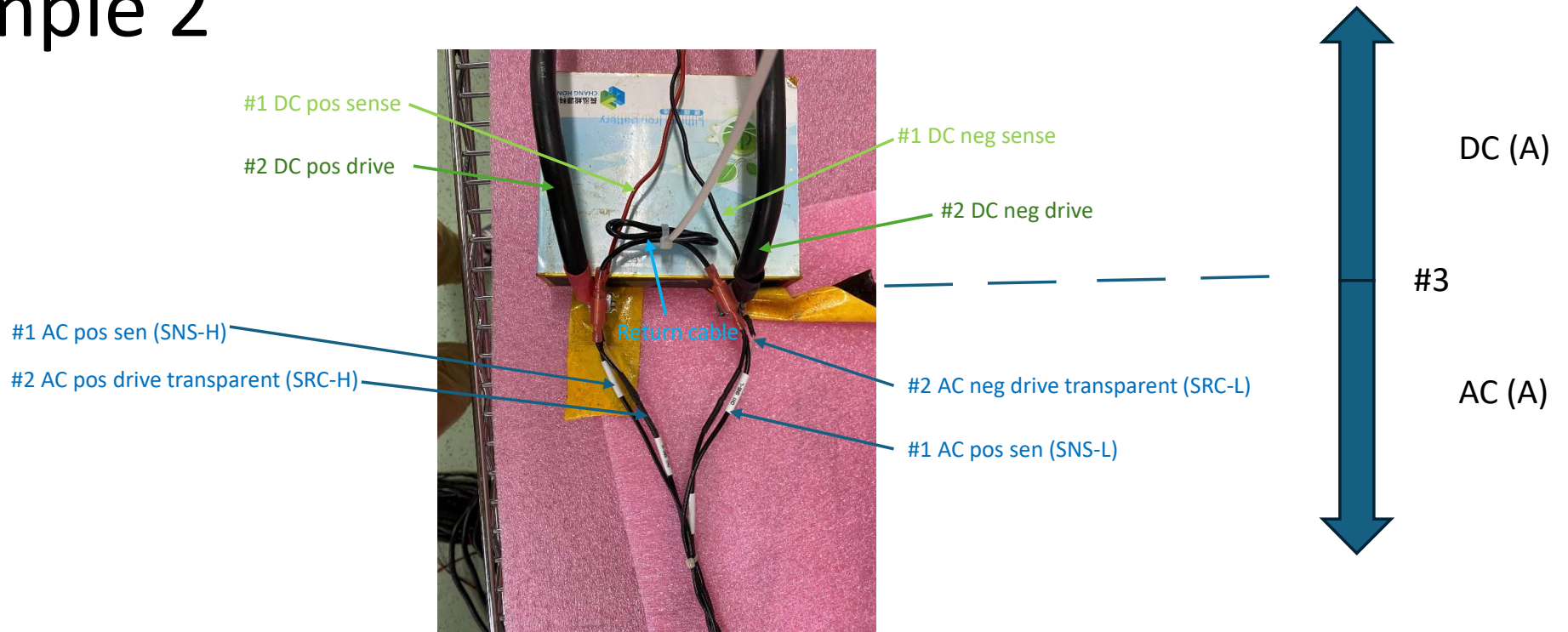

Do not cross AC (Hioki) and DC (Chroma) cables.

Test fixture

- You can also use a fixture and perform the zeroing if the previous method described is followed. Meaning as long as the test fixture is a four-wire measurement fixture.
- If you want to zero on the fixture you need to clamp the zero fixture (as long as the cell terminal distance). Do connect the AC senses firstly together and use a third short wire to connect to the middle point of the zero fixture. The AC drives must be connected to the out sides of the zero-fixture bar (see slide 9/17 as reference).



Lex software AC impedance measurement

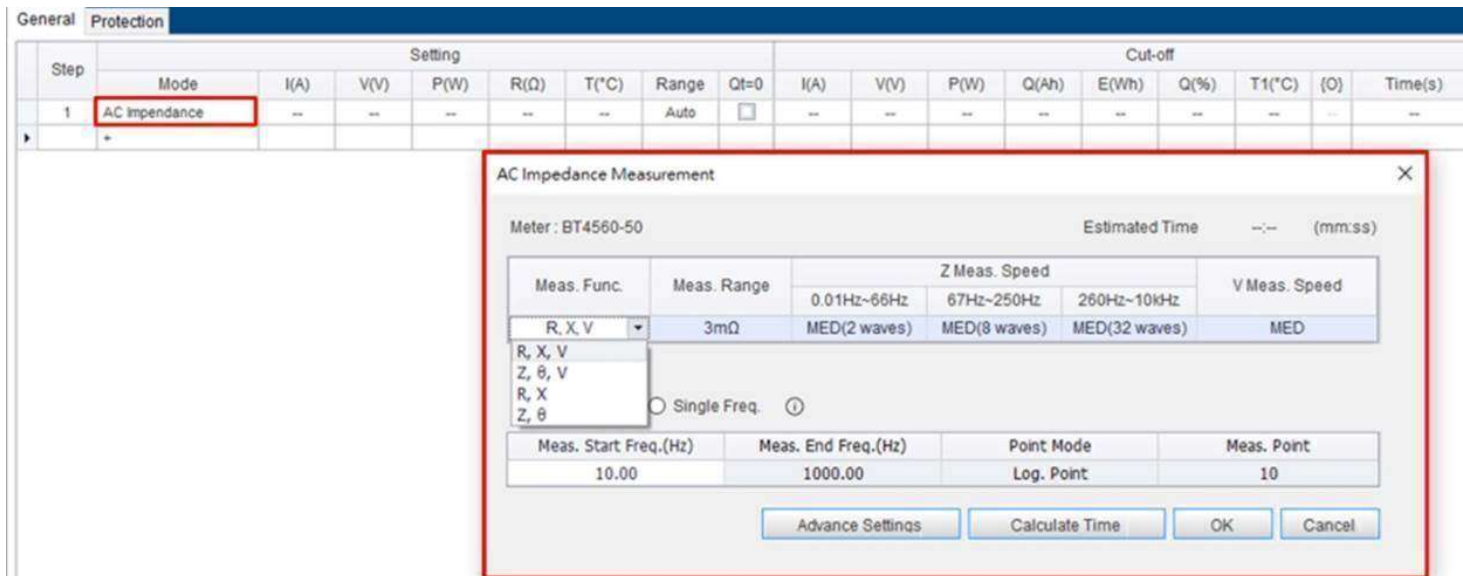

- You can add an AC impedance step in your SR (Sub recipe) and select one of the four measurement functions R,X,V or Z, θ , V, or R,X or Z, θ
- You can execute the SR as part of a TP (Test Plan). The results will be available for you in the Chroma Data Analyzer software.



Chroma

Driving Innovation to Success



Thank You