

# 17040E Regenerative Battery Pack Test System

## Product Field Training Manual

Product Manager Sharman Chang

Oct.2022

**Chroma ATE Inc.**

# Outline

- Key Features
- Promotion Material
- Ordering Information
- Others/Appendix
- Application & Regulation requirements
- Q&A



## BAG

87x0 Battery Pack Automatic Test System



## BAF

170x0 Regenerative Battery Pack Test System

# New Product 17040E Introduction

Specially designed for lithium battery pack

CHG/DSG test system, including four Model

- ❑ Voltage : 10V~1700V/ 5V ~ 850V
- ❑ Current : 400A/ 800A
- ❑ Power Rating : 200kW, 1.2MW in paralleling
- ❑ AC Input: 380-400V,3Φ4W / 440-480V, 3Φ4W

Model name	Description	Dimension (W x D x H, without roof)
69420E-1700-800	200kW/1700V/800A_1CH	230cm x 100cm x 190cm
69420E-850-800	200kW/850V/800A_1CH	230cm x 100cm x 190cm



200kW

High Accuracy

Voltage  
0.02+0.02%FS  
Current  
0.05%FS

High Power

Wide Voltage and Current Rating  
1700V / 400A  
850V / 800A

Driving Cycle Simulation

Current sink time  
(10%~90%)  
1ms

## Main SPEC

- Wide Voltage Range (850~5V / 1700~10V) ; used for packs and modules with constant performance
- Response Time (10~90%) is industry indicators 1ms
- Sampling time is industry indicators 1ms
  
- Voltage scale : the measurement accuracy for each state of applications
  - 1700V (HPC, ESS)
  - 1200V (High Voltage EV)
  - 600V (EV/ E-Bus)
  - 150V (Battery Module)
- Current Scale : First Battery Pack tester includes 4 measurement scales 400A/200A/100A/50A ·  
Better than competitors

# New Product 17040E Introduction

## Key Features

Support the below integration interface for SI company integrating convenience

- Ethernet (support SCPI, Labview, Labwindow)
- CANbus(Support CANbus command format and \*.dbc file)
- ISOLATION DI/DO (Through external part control 17040E into Interlock & EMO state. Through I/O to inform the external part the current state of 17040E.)
- Analog I/O port: Using voltage signal to control the device voltage and current

## Others

- 200kW parallel number: 6 sets · The max. power rating in parallel: **1.2MW**
- Solar Simulator Function(Release soon)
- The data mapping error : data logger <100ms
- The data mapping error : BMS <500ms

## Option

- DC output Isolation Monitoring function ° Option ISO685
- VDE-4105-AE Certification Device ° Option VDE meter ufr1001e

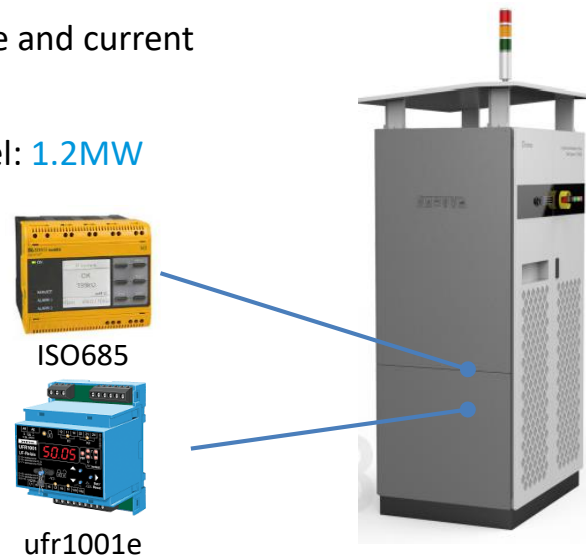

# New Product 17040E Introduction

## Key Features - System Integration Advantage

### 1. Hardware Control :

- a. BMS communication hardware integration for controlling : CAN, CANFD, LINbus, RS485
- b. 12V Power supply
- c. Water cooler control , Chamber integration

### 2. BMS Communication Function Control :

#### CANbus

- a. BMS data record (broadcasting)
- b. BMS data record (question-and-answer interactively)
- c. BMS data record (UDS SID 0x19, 0x22)
- d. Send BMS command to BMS (UDS, unlock)
- e. Send BMS command to BMS (Event)
- f. Send BMS command to BMS (Cycling, Heartbeat)
- g. Send BMS command with CRC and live-counter (Cyclin

#### CANFD

- a. BMS data record(broadcasting)

#### LINbus

- a. BMS data record (Client to server)
- b. BMS data record (Server to Client)

#### RS485

- a. BMS data record (Master-slave protocol)
- b. BMS data record (via MODBUS protocol)

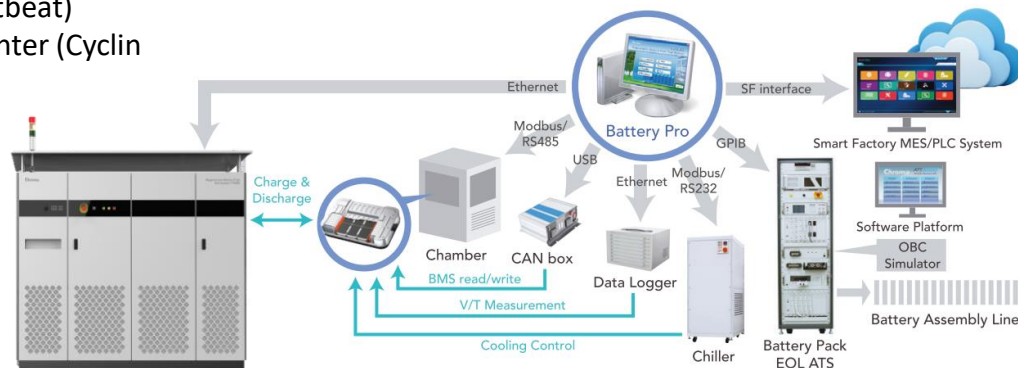

# Promotion Material

# 17040E Regenerative Battery Pack Test System

## Regeneration function Protection—fulfill anti-islanding test

- Efficiency > 90% · THD < 5% · PF > 0.95
- Stable AC voltage during regenerating
- Fulfill VDE-4105-AE (option) test requirement
  - Islanding detection, < 5 sec
    - Voltage drop  $V < 0.8 U_n$ , < 0.2 sec
    - Voltage rise  $V > 1.1 U_n$ , < 0.2 sec
    - Voltage rise  $V \gg 1.15 U_n$ , < 0.2 sec
    - Frequency decrease  $f < 47.5 \text{ Hz}$ , < 0.2 sec
    - Frequency increase  $f > 51.5 \text{ Hz}$ , < 0.2 sec
- Anti-islanding protection (Option)
  - Dual-breaker loss protection
  - VDE-4105-AE certification device °
  - Option VDE meter ufr1001e

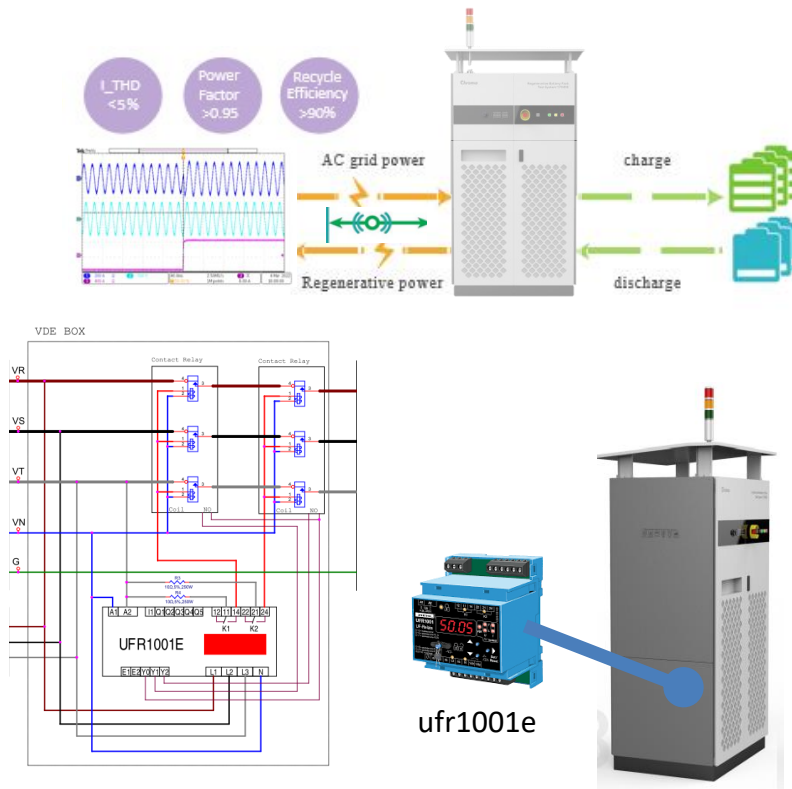

# 17040E Regenerative Battery Pack Test System

Strengthen the safety design of risk management

## ■ Primary protection, hardware protection

- 1) OVP/ LVP
- 2) OCP/ OTP/ Capacity Protection
- 3) Wire Loss Protection
- 4) Delta Protection :  $-\Delta V/ +\Delta V$  and  $+\Delta I/ -\Delta I$

## ■ Secondary software protection

- 1) Protection through BMS Data
- 2) Data Logger
- 3) Chamber Data
- 4) DI / O Port

## ■ Three-level hardware protection (optional)

- 1) Leakage Protection: DC output Isolation Monitoring Function
- 2) Optional ISO685

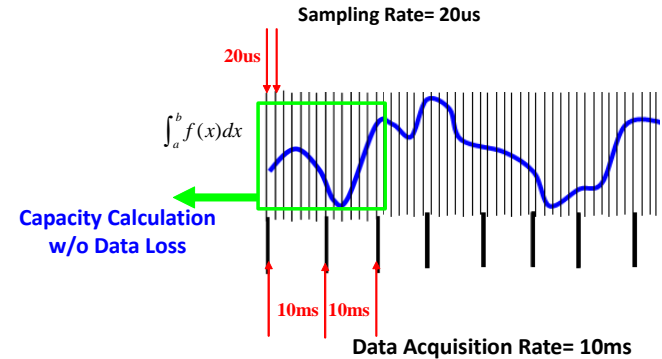

# 17040E Regenerative Battery Pack Test System

Strengthen the safety design of risk management

## ■ Four-level Protection, Independent Loop Protection.

While detecting system voltage, current abnormal, block out the output immediately

- 1) Communication · MCU abnormal
- 2) Module Feedback Exception
- 3) Communication signal detection abnormal
- 4) Over Voltage Protection

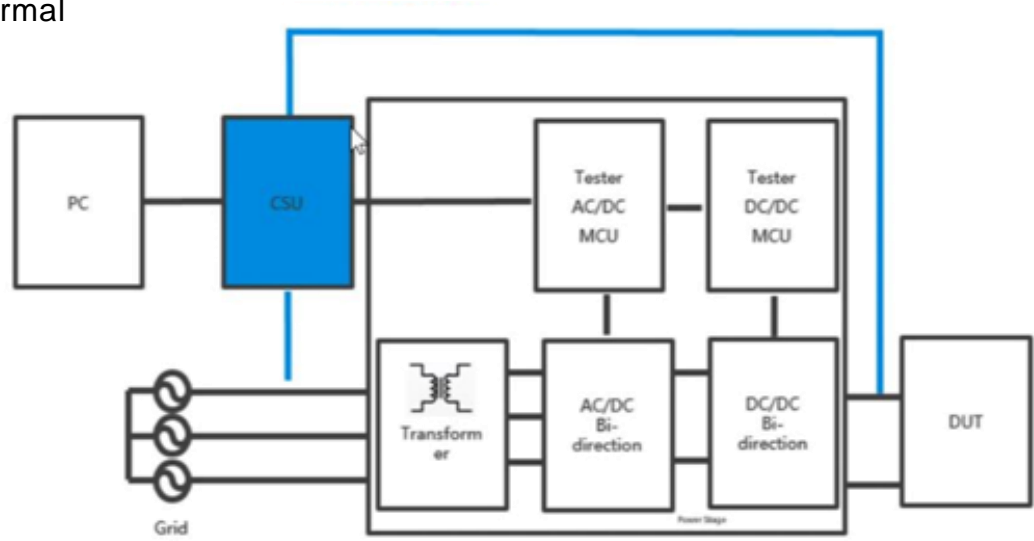

# 17040E Regenerative Battery Pack Test System

Two voltage and current operating ranges, more flexible application

## ■ Voltage and current operating range (69420E-1700-800)

- 1) 200kW/ 850V/ 800A
- 2) 200kW/ 1700V/ 400A

## ■ Voltage Accuracy and Scale :

- 1)  $\pm (0.02\% \text{ of rdg. } \pm 0.02\% \text{ of r.n.g.})$
- 2) First voltage scale : 1700V/ 1200V/ 600V/ 150V
- 3) Second voltage scale : 850V/ 600V/ 300V/ 75V

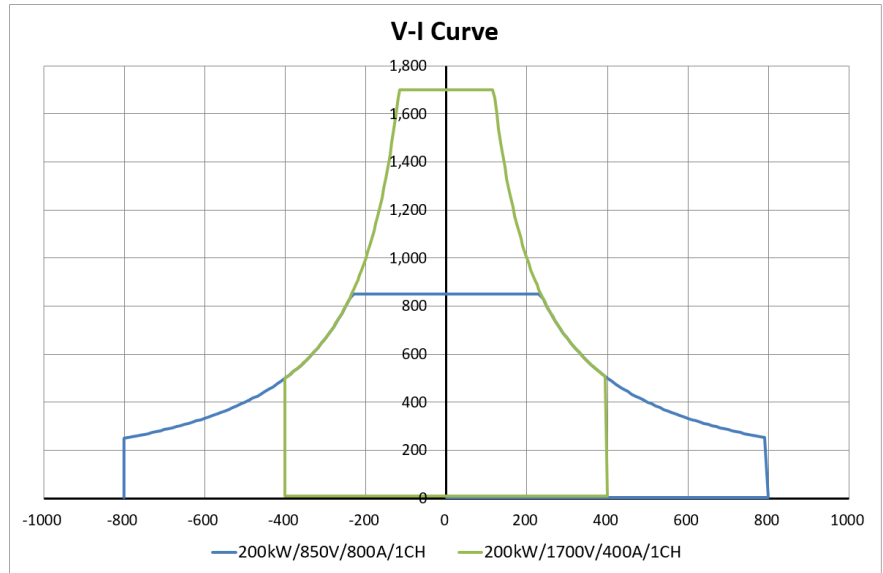
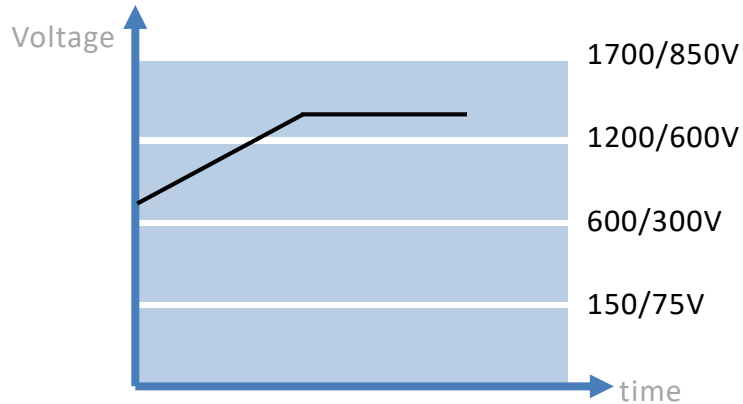

# 17040E Regenerative Battery Pack Test System

## Configuration Flexibility

Model name	Description	Parallel mode
69420E-1700-800	200kW/1700V/800A_1CH	Max 1.2MW • 600kW: 200kW x 3 • 1,200kW: 200kW x 6

200kW

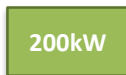

400kW



600kW



800kW



1MW



1.2MW





## Fast current response of dynamic drive curve simulation

- Quick Response Test Technology : 17040E is 1ms ( 10% to 90% )
- Stable Current, during the transition, there is no overshoot
- There is no interruption current from charge to discharge
- Dynamic charge/discharge power or current waveform fits the NEDC , FUDS and HPPC standard

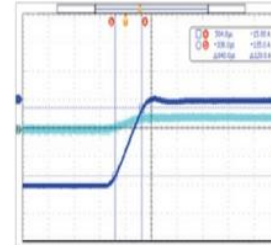

< 1ms (0% to 90%)

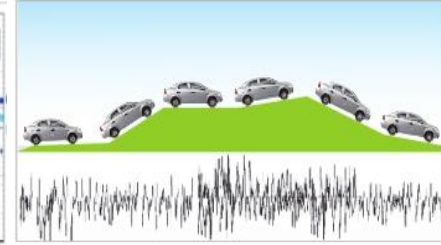

Driving profile simulation

## Accurate Measurement-Improve Product Quality

- Current Accuracy :  $\pm$  (0.05% of FS.)
- High-frequency sampling measurement technology
- Automatic voltage/current range switching function
- Current Ripple Noise<0.5%

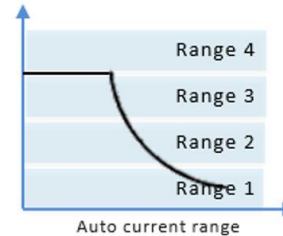

# 17040E Regenerative Battery Pack Test System

## Software - BATTERY PRO

- Real-time monitoring/icon design/fault record tracking in recipe executor
- Edit test steps in the user-friendly recipe editor
- Report Wizard in Data Analyzer



BatteryPro Main Panel



Recipe Executor



Recipe Editor

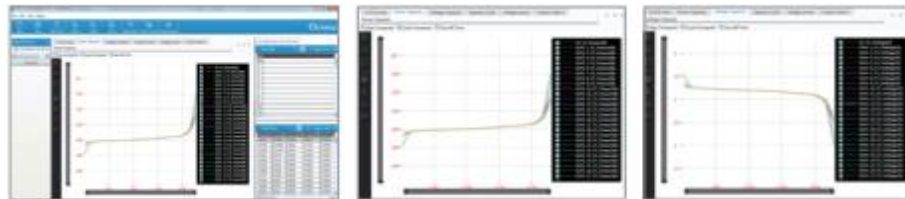

Data Analyzer

# 17040E Regenerative Battery Pack Test System

## Software - BATTERY PRO

### Recipe Editor

- Dynamic waveform simulation function
- IEC Certification
- Cycle life loop and cycle
- CAN Write BMS Control
- For measuring BMS protection function
- DCIR / EDLC Measurement

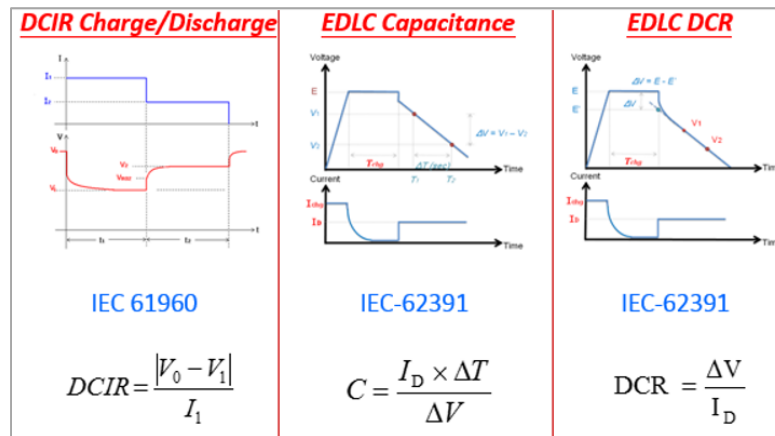
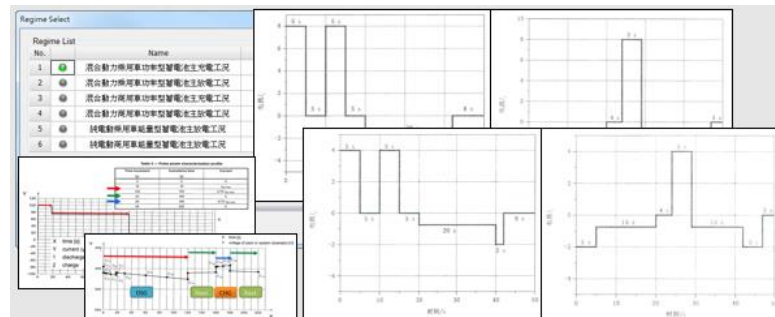
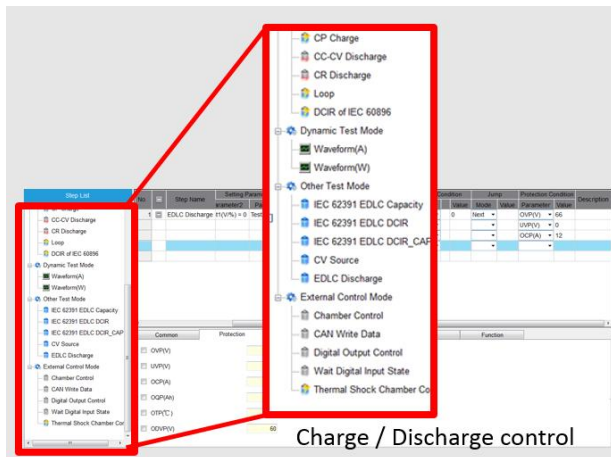

# 17040E Regenerative Battery Pack Test System

## Third-party Devices Integration Technology – convenience and save time

- Chamber
- Data Logger
- BMS data record/ control
- Water Cooler
- ECU simulator
- Others

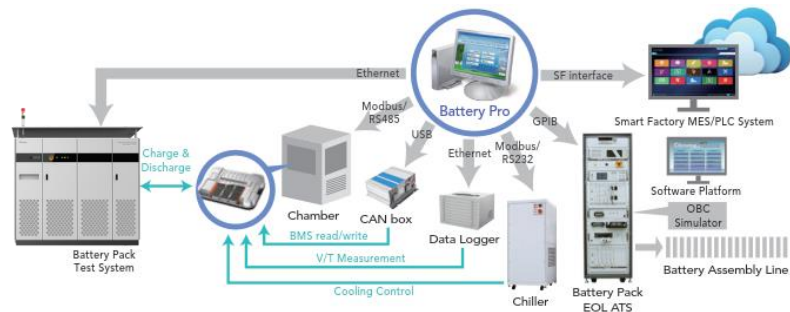

## BMS control waveform mode for driving cycle simulation test

### (Option) Control UUT through Unified Diagnostic Service (UDS)

- UDS unlock DUT :  
Tester present, session control, security access
- Record BMS data :  
UDS SID 0x19 for DTC code  
UDS SID 0x22 for BMS states.

### BMS Following Control

- Current, Power Rating Mode

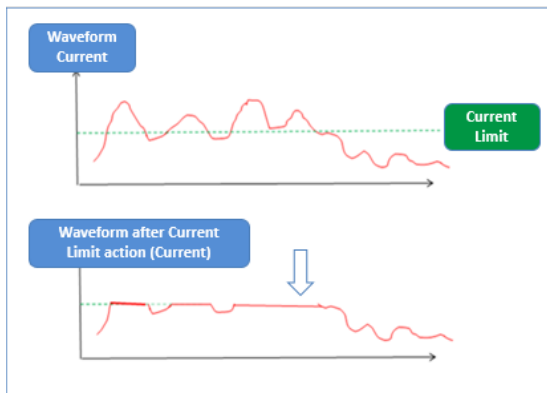

# BMS Communication

## CANbus/ CANFD Example

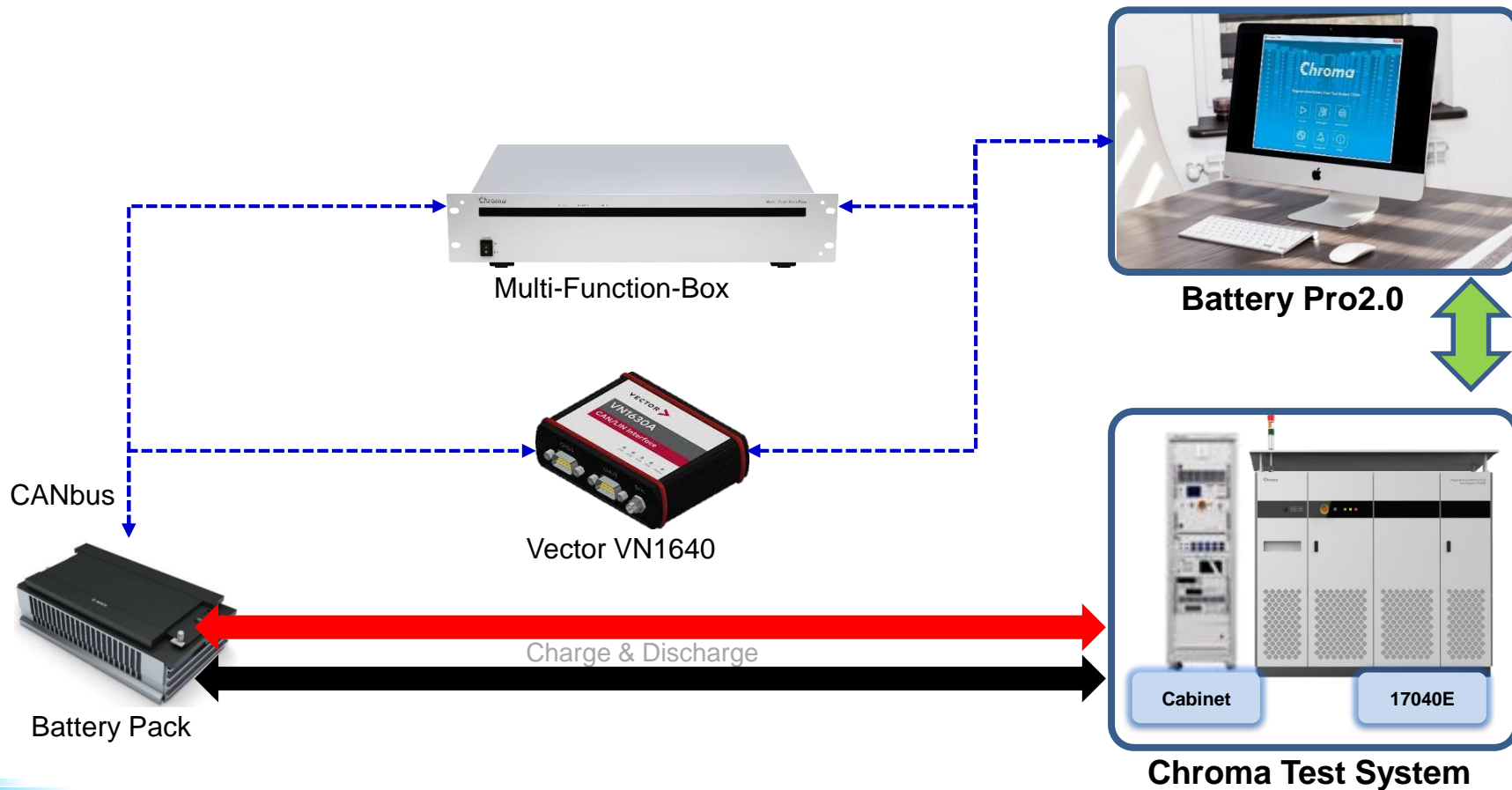

# 17040E Regenerative Battery Pack Test System

## BMS communication function of BatteryPro 2.0

	Device	Outsourcing (Vector)
	Description	16x0A
CAN	BMS data record (broadcasting)	●
	BMS data record (question-and-answer interactively)	N/A
	BMS data record (UDS SID 0x19, 0x22)	N/A
	Send BMS command to BMS (UDS, unlock)	N/A
	Send BMS command to BMS (Event)	●
	Send BMS command to BMS (Cycling, Heartbeat)	N/A
	Send BMS command with CRC and live-counter (Cycling, Heartbeat)	N/A
CANFD	BMS data record (broadcasting)	●
LINbus	BMS data record (Client to server)	N/A
	BMS data record (Server to Client)	N/A
RS232	BMS data record (Master-slave protocol)	N/A
RS485	BMS data record (via MODBUS protocol)	N/A

● Included

1. BMS communication via CANbus: Using Vector VN16x0
2. Max channels of CANbus communication: 4CH for one unit of Battery pack
3. Data acquisition time of CANbus communication device minimum sampling time:  
36 CANID/10ms,  
360 CANID/100msec,  
3600 CANID/1sec at 1M baud rate
4. The time synchronization between BMS CANbus communication device and the data of Chroma tester : <500ms

**(Chroma offers CAN-Bus Communication for 17040E systems that can be used to communicate with the Battery Management Systems (BMS) of battery packs during battery test. The CAN-Bus function of 17040E system supports reading, writing, and sending CAN messages, logging, monitoring, setting, controlling, and protecting the battery pack.**

**Chroma follows the standard CAN-Bus specification such as CAN2.0A and CAN2.0B protocol or user-defined protocols.)**

# 17040E Regenerative Battery Pack Test System

## BMS communication function of BatteryPro 2.0

	Device	J 87200001
	Description	Multi-Function Box-D
CAN	BMS data record (broadcasting)	N/A
	BMS data record (question-and-answer interactively)	N/A
	BMS data record (UDS SID 0x19, 0x22)	N/A
	Send BMS command to BMS (UDS, unlock)	N/A
	Send BMS command to BMS (Event)	● *2
	Send BMS command to BMS (Cycling, Heartbeat)	● *3
	Send BMS command with CRC and live-counter (Cycling, Heartbeat)	● *4
CANFD	BMS data record (broadcasting)	N/A
LINbus	BMS data record (Client to server)	N/A
	BMS data record (Server to Client)	N/A
RS232	BMS data record (Master-slave protocol)	N/A
RS485	BMS data record (via MODBUS protocol)	N/A

● Included

- (1) Editor design Pre test and Post test
- (2) Pre test : Preparing for DUT or Equipment state
- (3) Post test : Resetting for DUT or Equipment state
- (4) The major category is to establish Pre-test and Post-test under Special Mode
- (5) Pre-test and Post-test will pop up to select XML file window, XML file can set CANbus message sending rules

No.	Step Name	Setting Parameter				Cut-Off Condition		Jump		Protection Condition		Description	
		Parameter1	Parameter2	Parameter3	Parameter4	Sampling	Value	Parameter	Value	Mode	Value		Parameter
	Pre-test	Select File = Pre-test1-ethan											
1	REST					Time(sec)	3	Time(sec)	>=	100:0:0	Next	OVP(V)	66
												UVP(V)	0
												OCV(A)	12
	Post-test	Select File = Post-test2-CH3											

# Ordering Information

# Ordering Information

MODEL NO.	PRODUCT DESCRIPTION
17040E	Regenerative Battery Pack Test System
69420E-1700-800 #E, #F	Modular AC/DC Bidirectional Power Stage, 200kW/1700V/800A/1CH, AC input 380Vac (380-400V, 3Φ4W)
69420E-1700-800 #E, #F	Modular AC/DC Bidirectional Power Stage, 200kW/1700V/800A/1CH, AC input 440Vac (440-480V, 3Φ4W)

INDIVIDUAL ITEM	
A170402	17040E Battery Pro Software
A170202	Battery Simulator soft-panel
Option	
Vector VN1630	CAN Network Interface USB-Interface for CAN (2x CAN, 2 x additional plug-in locations for CAN/LINpiggy ).(w/ cable, w/o CANpiggy 1057Gcap)
Vector VN1640	CAN Network Interface USB-Interface for CAN (4 x additional plug-in locations for CAN/LINpiggy ).(w/ cable, w/o CANpiggy 1057Gcap)
Vector VN1630/1640 accessories	CANpiggy 1057Gcap (shipping with VN1630 or VN1640)/ CANpiggy 1057Gcap (shipped individually)
J 87200001	Multi-Function Box-D (4CH CANbus,2CH CANFD, Support UDS)
	WOOD BOX for 200/300kW of 17040E
A170402	17040E Battery Pro Software
A170202	Battery Simulator softpanel
DC output cable	DC Output cable 3 meters
	DC Output cable 5 meters
	DC Output cable 10 meters
	DC Output cable 15 meters
AC input cable	AC Input cable 5 meters
	AC Input cable 10 meters

Control Interface for System integrator*14	
Communication Interface	CANbus
Connector	1 x DB9 male connector
Channels	1CH
Protocol	CAN 2.0A (11-bit) / Extended CAN 2.0B (29-bit)
Data Transfer Rate	Up to 1 Mbit/s via CANbus
CAN Transceiver	ADM3054 (Compatible with ISO 11898-2)
Signal Support	CAN_H, CAN_L
Isolation Protection	5 kV rms signal isolated CAN transceiver

Control Interface for System integrator*14	
Safety Interface	Digital Input/ Output interface for Safety
Isolated Digital I/O	32 ports input pin/ 32 ports output pin
Isolated Digital Input	Logic 0 (VIL) : 0~0.8V / Logic 1 (VIH) : 1.2Vmin (24 V max.)
Isolated Digital Output	Output Type: Dry Contact (Open: high; Close: Low) / Output Voltage 5 ~ 24 VDC/ Sink Current 1A max

Control Interface for System integrator*14	
Communication Interface	Analog programming interface*
Analog Output (measurement Volt. & Current)	2 ports (2 wires)
Voltage and Current monitor/ Programming (Resolution/ Voltage Range/ Response time/ Input Impedance)	16 bit/ $\pm 10V$ / <3ms/ 10 Mohm
Analog Input (Current control)	1 port (2 wires)
Analog Input (Voltage control)	1 port (2 wires)
Latency time	5ms

# APPLICATIONS

Common tests & regulation requirements

## CAPACITY TEST

The capacity can be obtained as the integral of the discharge current versus time, which requires test equipment with high current accuracy. Although each battery comes with specifications indicated by the manufacturer, these often use capacity testing at low charge/discharge rates, whereas power battery applications are usually charged and discharged at high rates, thus leaving a gap between the specification and the actual capacity. Chroma 17040E refers to the final charge/discharge rates of the power battery and gives a more accurate battery capacity.

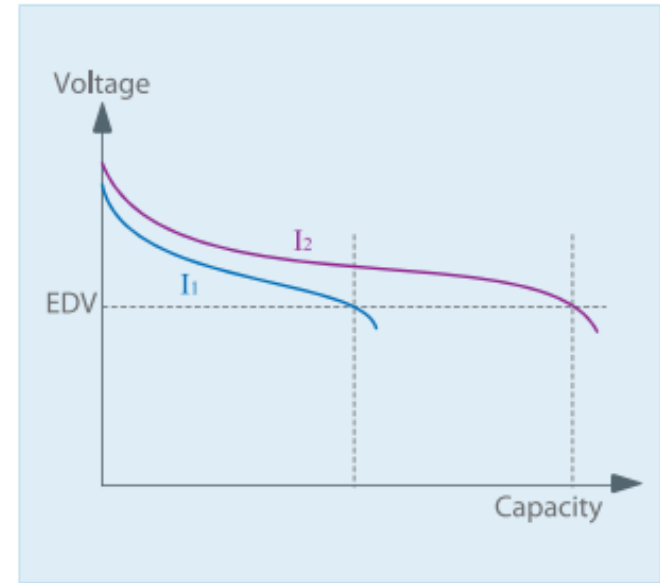

Capacity Test

# Applications

## CYCLE LIFE TEST

Cycle life is a highly important test item for batteries. Chroma 17040E uses user-defined charging and discharging conditions as a cycle and tests the same battery repeatedly until the capacity reaches the cut-off power condition. The larger the number of successful cycles, the longer the cycle life of the battery. Testing under the same test conditions is useful to evaluate the performance of different battery products or define the applicable conditions of use

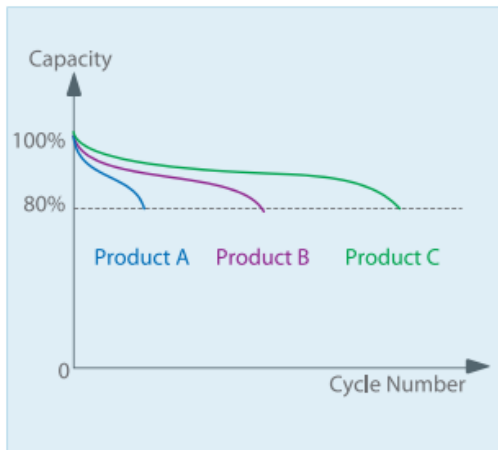

Cycle Life Test

No.	+	Step Name	Parameters	
			Parameter1	Parameter2
1	+	CC-CV Charge	V(V) = 600	I(A) = 250
2	+	CC Discharge	I(A) = 500	$\Delta V(V)$ Sampling Time(Sec) = 3
3	+	Loop	Start step of Loop = 0	Loop Count = 500

# Applications

## BATTERY DCIR TEST

The internal resistance value is related to the charge/discharge ratio of a battery. The larger the internal resistance value, the lower the efficiency when temperature rises. According to the lithium-ion battery equivalent circuit model, traditional ACIR measurement of 1KHz LCR meters can only evaluate the battery's conductive resistance ( $R_o$ ) that affects the instantaneous power output, but is unable to evaluate the polarization resistance ( $R_p$ ) produced during electrochemical reaction. DCIR evaluation includes the ACIR, and is closer to the actual polarization effect of batteries under continuous power application. Chroma 17040E calculates the DCIR value using the voltage difference caused by the two-step current change, without any manual calculation, and automatically obtains the test results compliant with IEC 61960 °

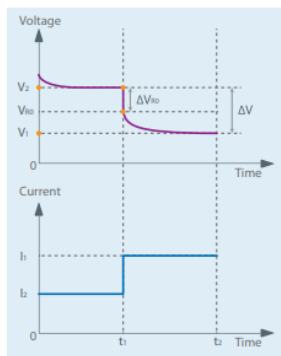

DCIR Test

$$DCIR = R_o + R_p = \frac{\Delta V}{\Delta I} = \frac{|V_2 - V_1|}{|I_1 - I_2|}$$

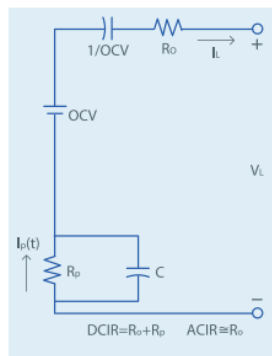

Li-ion battery Equivalent Circuit Model

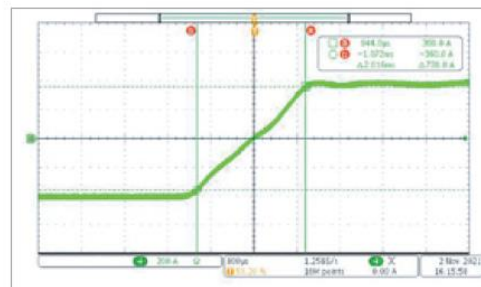

Discharge to charge:

Current slew rate < 2ms (-90% to 90%)

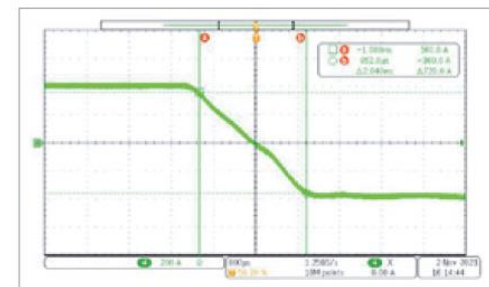

Charge to discharge:

Current slew rate < 2ms (-90% to 90%)

# Regulation - Battery

- IEC62619 - **Safety** requirements for secondary lithium cells and batteries, for use in industrial applications
- IEC62620 - Secondary lithium cells and batteries for use in industrial applications

## IEC62619

1. Charging procedure for test purposes
2. External short-circuit test (cell or cell block)
3. Impact test (cell or cell block)
4. Drop test (cell or cell block, and battery system)
5. Whole drop test (cell or cell block, and battery system)
6. Edge and corner drop test (cell or cell block, and battery system)
7. Thermal abuse test (cell or cell block)
8. Overcharge test (cell or cell block)
9. Forced discharge test (cell or cell block)
10. Considerations for internal short-circuit – Design evaluation

## IEC62620

### Discharge Performance

Discharge performance at +25 °C  
 Discharge performance at low temperature  
 High rate permissible current

### Charge (capacity) retention and recovery

General  
 Test method  
 Acceptance criterion

### Cell and battery internal resistance

General  
 Measurement of the internal a.c. resistance  
 Measurement of the internal d.c. resistance

### Endurance

Endurance in cycles  
 Endurance in storage at constant voltage (permanent charge life)

# Regulation - BESS

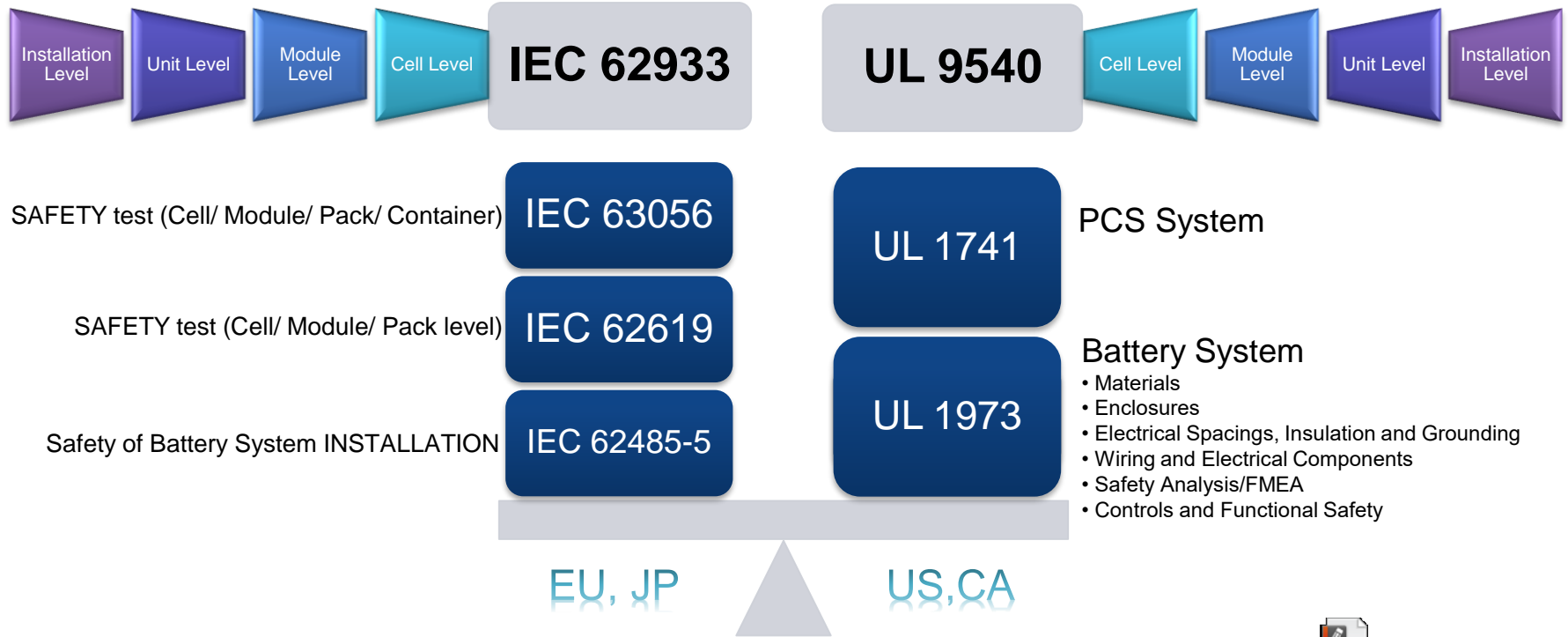

# Q & A

# THANK YOU

**Chroma** *Driving Innovation to Success*

Get more information in the APP

